

# Operating Manual

## 300 SERIES

S327 & S330

Equipped With HATZ 4H50-TIC Diesel Engine and Fluid Coupling  
Engine U.S. EPA Tier 4F Certified

Self-Contained Refractory Walled Air Curtain Burner



***“Better Economically - Better Environmentally”***

**MADE IN THE USA**

*Factory and Main Office*

**Air Burners, Inc.**  
4390 SW Cargo Way  
Palm City, FL 34990

Phone: 772-220-7303  
888-566-3900

E-mail: [support@airburners.com](mailto:support@airburners.com)

*Visit Our Website at*  
**[AirBurners.com](https://www.AirBurners.com)**



---

© 2024 Air Burners, Inc. All Rights Reserved.  
Subject to change without notice. Dimensions & metric conversions rounded. The words *Air Burners*, *BurnBoss*, *CharBoss*, *TrackBoss*, *BioCharger* and the *Air Burners Logos* are Registered Trademarks of Air Burners, Inc.

### WARNING

Should any repairs become necessary that require welding on your FireBox, you **MUST** first physically remove the Electronic Control Module (ECM) from the computer controlled Diesel engine (Applies to both 3H50 and 4H50). Follow the instructions below.

#### ECM Removal Steps

1. Wear Personal Protective Equipment (PPE).
2. Ensure engine is switched off and cold.
3. Disconnect negative battery cable.
4. Unsnap Latches 1 and 2.
5. Remove Bolts A1 and A2.
6. Unplug both connectors.
7. Remove Bolts B1, B2, B3 and B4.
8. Remove the two brackets.
9. The ECM can now be removed and stored away while repairs are made.
10. Re-install all in reverse order.

#### PERSONAL PROTECTIVE EQUIPMENT (PPE) & WOOD ASH CAUTION:

Always wear appropriate Personal Protective Equipment (PPE) while working with the FireBox, especially a breathing apparatus like a respirator while removing wood ash from the firebox (burn chamber) and while handling the wood ash. See also Page 7.



### WARNING:

**Please, read and understand all Caution and Warning Notices and Operating Instructions before working with the FireBox and always follow them diligently. Disregarding these important Notices may lead to an accident that may result in property damage, serious personal injury, or death.**

Contact Air Burners, Inc. Customer Service should you require any assistance. Send Email to [support@airburners.com](mailto:support@airburners.com), call 772-220-7303 or 888-566-3900.

## INDEX

WELDING REPAIR WARNING .....	Page i
WARNINGS.....	Page iii
PRINCIPLE OF AIR CURTAIN INCINERATION .....	Page 1
GENERAL DESCRIPTION OF S-SERIES .....	Page 2
SAFETY CONSIDERATIONS .....	Page 5
HOW TO SET UP THE MACHINE .....	Page 8
SITE PREPARATION .....	Page 13
LOADING AND STARTING THE FIREBOX .....	Page 14
HOW TO FEED A FIRE .....	Page 18
SHUTDOWN .....	Page 19
ASH REMOVAL .....	Page 20
TROUBLESHOOTING .....	Page 22
MAINTENANCE AND CARE .....	Page 23
SERVICING SPECIFICATIONS .....	Page 25
LIFTING POINTS .....	Page 26
CHECKING COUPLING ALIGNMENT .....	Appendix A
HATZ ENGINE OVERVIEW (COMPONENT IDENTIFICATION) .....	Appendix B



**300 Series Air Curtain Burner with HATZ 4H50 Diesel Engine & Fluid Coupling  
OPERATING MANUAL**

---

**PERSONAL PROTECTIVE EQUIPMENT (PPE)  
& WOOD ASH CAUTION:**

Always wear appropriate Personal Protective Equipment (PPE) while working with the FireBox, especially a breathing apparatus like a respirator while removing wood ash from the firebox (burn chamber) and while handling the wood ash. See also Page 7.

**WARNING:**

**PINCH POINT HAZARDS**

Be mindful of Pinch Point Hazards. Keep your hands clear from all moving parts and hot parts of the FireBox while it is being set up or in operation.

**IMPORTANT WARNING ABOUT THE BURNING OF PALLETS:**

Wooden Pallets, especially spent pallets, burn extremely hot. **DO NOT** load the FireBox above approximately 3/4 of the height of the burn chamber. Heat damage to the manifold and other structure may occur which would not be covered under your Limited Factory Warranty.

**CUSTOMER SUPPORT:**

Contact Customer Support at Air Burners, Inc., should you require assistance with any maintenance task or should you have any questions regarding the setup or operation of your FireBox.

Email: [support@airburners.com](mailto:support@airburners.com) Phone: 772-220-7303 or 888-566-3900



**S327**



**S327**

## PRINCIPLE OF AIR CURTAIN INCINERATION

### OPERATION

Air curtain incinerators (also called air curtain burner or FireBox) are designed primarily as a pollution control device. Using a Diesel engine driven fan, these machines generate a curtain of air with a very particular mass flow and velocity. This curtain of air acts as a trap over the top of an earthen trench or thermal-ceramic lined firebox (burn chamber). The wood debris is dumped into the trench or firebox and then ignited (usually with a propane torch or with a small amount of diesel fuel where permitted) just as you would light any other pile of wood you intended to burn. Once the fire has gained strength the air curtain is turned on.

The air curtain traps most of the smoke particles and causes them to re-burn directly under the air curtain where the temperatures can exceed 1800° F (≈1000° C). These machines do not inject any fuels into the fire, the fire is sustained only by adding more wood feedstock. The air from the air curtain is not heated. The only fuel used in the continuous operation is that for the Diesel engine that powers the air fan.

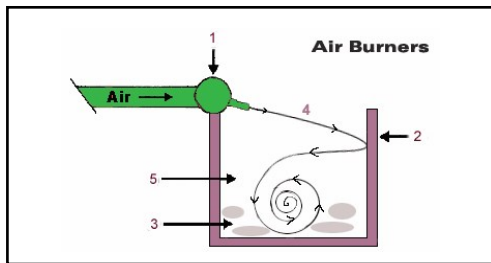

[Click Here](#) or Scan  
for Video  
"Open Pile Burning  
vs FireBox Burning"

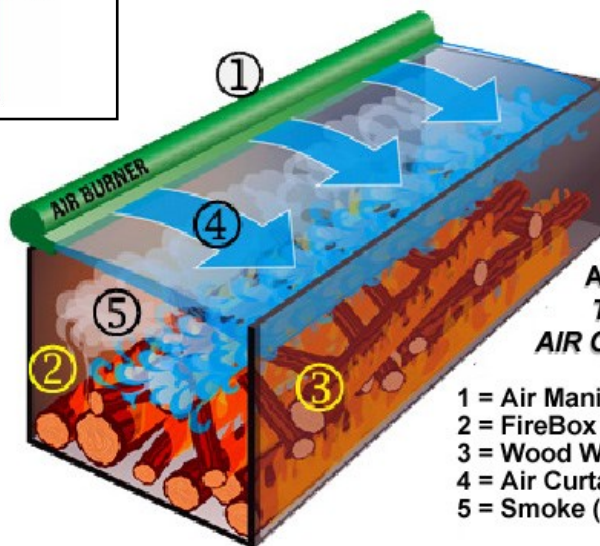

**AIR BURNERS, INC.  
THE PRINCIPLE OF  
AIR CURTAIN BURNING**

- 1 = Air Manifold
- 2 = FireBox Refractory Wall
- 3 = Wood Waste or Wood Fuel
- 4 = Air Curtain (left to right)
- 5 = Smoke (PM or Black Carbon)



# 100 Series Air Curtain Burner with HATZ 4H50 Diesel Engine & Fluid Coupling OPERATING MANUAL

## GENERAL DESCRIPTION S-SERIES

The self-contained refractory walled air curtain system is manufactured as an over-the-road transportable combustion system designed to reduce clean wood waste and vegetative growth to ash in a safe, controlled burning process without excessive particulate emissions. The FireBox is open to the ground (soil surface), except for the Roll-off versions; they have a floor to accommodate the roll-off rail system. The standard S-Series machines are offered in several sizes. The smallest is the S116 (16 ft. firebox) and the largest is the S330 (30 ft. firebox).

The T26 CharBoss is a trailer-mounted street-legal Biochar processor designed to optimize production of high-grade Biochar. The self-propelled T28 TrackBoss is similar to the T24 BurnBoss, however, with the trailer frame replaced by a remotely controlled track system.

Above-Ground Air Curtain Burner Dimensions					
Model	Overall Size L x W x H	Firebox L x W x H	Weight lbs.	Fuel gal/hr.	Average Thru-put* tons/hr.
<b>S330</b>	40' 4" x 11' 10" x 9' 6"	30' 2" x 8' 5" x 8' 1"	59,000	3.0	11-13
<b>S327</b>	37' 4" x 11' 10" x 9' 6"	27' 2" x 8' 5" x 8' 1"	54,600	3.0	9-11
<b>S223</b>	33' 3" x 8' 6" x 8' 6"	22' 11" x 6' 2" x 7' 1"	40,250	2.0	7-9
<b>S220</b>	30' 1" x 8' 6" x 8' 6"	19' 8" x 6' 2" x 7' 1"	36,650	2.0	5-7
<b>S119</b>	27' 3" x 7' 2" x 7' 4"	19 x 5' x 6'	30,100	1.9	3-5
<b>S119R**</b>	27' 6" x 7' 2" x 8' 3"	19 x 5' x 6'	39,900	1.9	3-5
<b>S116</b>	24' 7" x 7' 2" x 7' 4"	16' x 5' x 6'	27,500	1.9	2-4
<b>S116R**</b>	24' 11" x 7' 2" x 8' 3"	16' x 5' x 6'	36,300	1.9	2-4
<b>T28</b>	17' 10" x 8' 5" x 5' 8"	12' x 4' x 4'	15,350	1.1	½-1
<b>T26</b>	21' 8" x 7' 8" x 6' 8"	12' x 4' x 4'	17,500	1.1	½-1
<b>T24</b>	19' 8" x 7' 8" x 5' 8"	12' x 4' x 4'	9,980	0.56	½-1

\* Approximate values. Achievable through-put depends on nature of waste stream and other factors.

\*\* Cable-hoist version; Hook-lift version is 5" shorter with 54 gal. min. capacity fuel tank.

- FireBox** S330 & S327: HATZ 4H50TIC (Tier 4 Final) or equivalent engine.
- Diesel Engine Version:** S223, S220, S119, S119R, S116 & S116R: Tier 4F HATZ 4H50TIC or optionally HATZ 3H50TIC or equivalent engine.
- Drive System:** Fluid Coupling (Automatic Clutch) & mechanical direct coupling drive. Manual PTO as option.
- Electric Motor Version:** Motor: 3-Phase, heavy-duty, with enclosed pre-programmed variable frequency speed controller (VFD); Power in: Three Phase 480V, 50Hz or 60Hz, or selected other voltages, i.e. 415V or 400V; Drive System: Direct drive.
- Options:** Ash clean-out rake - price will be quoted for plain faceplate (S300) or universal quick disconnect (S200 & S100).
- Fuel Consumption:** Indicated fuel consumption rates approximated.
- Through-Put:** Through-put depends on many factors, such as nature and type of wood waste, its moisture content, prescribed opacity limits, operator skills, elevation of location, etc. The figures stated here are guidelines only. If more specific information is required, please contact the Customer Support.
- NOTES:** All weights and dimension are approximate. Dimensional drawings can be provided on request. Subject to change without notice.

## **GENERAL DESCRIPTION S-SERIES**

When delivered to a job site, the S-Series machine is ready for use as soon as it is off-loaded. The entire system is built on a skid type base frame which is designed for easy movement over the earthen ground. The forward equipment deck supports a Diesel engine, a fuel tank, the direct drive system and the air fan. When viewed from the front of the unit, the patented air disbursement manifold is mounted on the left top side of the firebox (combustion chamber). The firebox is lined with proprietary thermal-ceramic refractory panels. The panels are cured prior to installation at the factory to drive out any moisture to ensure they are stable at first use in the field. The back of the firebox is fitted with refractory lined doors that allow ash removal and access to the firebox (only when it is completely empty).

The Diesel engine is coupled through a fluid drive (automatic clutch) that turns the air fan. The high velocity air is sent down the manifold through the vanes and directed to the outlet nozzles. A balanced and distributed air flow is directed across the top of the firebox (burn chamber) and then reflected down into the combustion zone.

The curtain of air acts as a lid over the firebox (burn chamber) trapping a large percentage of the escaping particulate matter (smoke or "Black Carbon") and causing it to burn down even further in the hot zone immediately below the curtain before finally escaping through the curtain visible as a hot gas. The air from the nozzles travels across the firebox creating the air curtain effect, then it reflects off the far side thermal-ceramic wall, adding oxygen to the combustion zone helping to generate a hotter more complete fire. This additional agitation helps prevent the fire from starving for oxygen as the ash builds up during burning operations.

### **NOTICE:**

All of this is carefully engineered to provide the correct amount of air at the correct velocity. It is sometimes thought that more air flow will actually increase the burn rate. This is **INCORRECT**. Modifying the air flow will actually have the opposite effect and reduce the machine's throughput. Additionally, it will reduce the machine's ability to meet minimum air quality standards. There is a maximum rate at which wood can burn. Trying to exceed that rate by adding more air to an air curtain burner causes two major problems:

1. It will cool the fire reducing combustion efficiency which will create more smoke (enriched with more carbon dioxide and oxides of nitrogen). This will begin a circular effect of further reducing the oxygen and further reducing combustion efficiency. The result is your throughput drops and smoke increases.
2. Increasing the air flow beyond design standards will over pressurize the firebox causing larger sized particles to be ejected from the firebox. Besides violating the EPA limits for PM (particulate matter) the larger hotter embers ejected will pose a much greater fire hazard.





S327 FireBox in Operation



S327 FireBox Rear Doors (Open)

**IMPORTANT:**

Notice how dirt is placed all around the inside bottom rails to close any openings under the skids that may be the result of uneven earthen terrain? This will prevent smoke from escaping. The FireBox must be placed on well-leveled soil (dirt), never on surfaces like concrete slabs, gravel, crushed stones or asphalt.

## SAFETY CONSIDERATIONS

### **READ ALL SECTIONS OF THIS MANUAL BEFORE YOU BEGIN BURNING OPERATIONS**

The S-Series machine operator is dealing with fire on a daily basis; it is very important that each and every individual involved with the machine be alert and practice very rigid safety precautions.

When you are running the FireBox, you are responsible for assuring that it is operated in the safest possible manner at all times. If you notice something wrong, correct it immediately. If you cannot correct it, find someone who can and/or shut down the machine.

#### **Basic Safety Points:**

1. **The unit must be placed on cleared, level ground.**  
The unit should be placed on level ground directly on the soil surface (dirt) to facilitate loading, dumping and moving of the unit. The rear doors weigh approximately 2,000 lb. each and should not be opened if the unit is inclined on any axis more than 5 degrees.

2. **The unit should be placed such that no combustible material is stored within a minimum 100 ft. clearance in any direction and never on a concrete pad or gravel stones.**  
The S-Series units do not have a bottom and must not be located over combustibles such as dry grass or peat moss which may cause a fire to spread to other areas. It is equally important not to place the standard FireBox on anything other than earthen soil, never on a concrete pad, gravel or crushed stones. There is a good reason for this warning. Concrete or gravel can contain water which the heat in an operating firebox could vaporize quicker than it can be drawn out. This could result in increased vapor pressure that can cause the concrete or stones to explode. Fragments could possibly fly out of the firebox and cause injury or death to persons nearby.

In addition *hot embers* will escape from the firebox and, depending on the wind, will land on the ground around the unit. The unit should not be located within 100 ft. of any stored combustible materials. The waste material to be burned during the day's operation can be staged within the 100 ft. perimeter to facilitate loading. The operator must monitor the loading pile to ensure embers do not ignite the loading pile. The combustible materials to be stored for burning at a later date must be stored outside the 100 ft. perimeter or in accordance with the chart on page 6 of this manual which suggests adjustments for wind speed.

3. **The unit should not be operated when the wind speeds reach 20 mph as the potential to carry hot embers is significantly increased.**  
As an operator you should always be aware of wind speed and direction. Increased wind speed will affect the integrity of the "air curtain" and will cause hot embers to travel farther. See the wind speed chart regarding suggested set back on page 6.

### **WARNING:**

**Watch for, read, and understand the CAUTION and DANGER NOTICES you will find throughout this operating manual. Failure to heed these warning notices could result in an accident causing property damage and serious personal injury or death.**

**100 Series Air Curtain Burner with HATZ 4H50 Diesel Engine & Fluid Coupling  
OPERATING MANUAL**

4. **NEVER use highly combustible materials to light the unit.**  
Highly combustible materials such as gasoline, refined spirits, etc. ignite at an explosive rate which may cause an accident resulting in serious injury or death. The safest method to start the fire in the firebox is to use wood waste materials such as kindling wood. In the absence of these materials or when starting feedstock with a high moisture content, use diesel fuel as an acceptable option if permitted..
5. **NEVER climb on the unit to view or light the fire.**  
Use the ladder built into the unit and never go beyond the top step, or use a step ladder or similar platform located at a safe distance from the unit. Do not stand along the rails or on top of the S-Series unit under any circumstance.
6. **Shut the FireBox down in an emergency.**  
Stop loading the unit, stop the air flow by shutting down the engine. Dump dirt or sand on to the fire. Water should only be used as a last resort, as it will likely damage the refractory panels.

**DANGER:**

**Do not sit or stand on the roof of the equipment deck or the rails of the FireBox. Falling off the machine or into the firebox will cause an accident resulting in serious injury or death.**

<b>WIND SPEED VS. SAFE DISTANCE</b>			
Wind Speed mph	Approximate Safe Distance for:		
	Structures (Houses, etc.) ft.	Woods/Trees ft.	Stored Brush Piles ft.
10	300	150	100
12	300	150	100
14	300	200	150
16	400	250	150
18	400	250	200
20	500	250	200

**DANGER:**

**The above distances serve as a GUIDELINE ONLY! You MUST ALWAYS observe the down range area regardless of the wind speed.**

**You must always observe local fire ordinances and directives from the local fire department or other competent authorities.**

## 7. Personal Safety (Personal Protective Equipment – PPE)

Operators must be aware of the following potential hazards:

- a. **Flying hot embers** being released from the fire. Operators or anyone within a 100 ft. radius of the fire should wear appropriate Personal Protective Equipment (PPE) including fire resistant clothing. The ideal outerwear for an operator would include a Nomex jacket, leather gloves, eye protection, hard hat, cotton work jeans and steel toe boots. Operators should never wear synthetic material (i.e., polyester) around a fire as this type of material can melt and cause injury. Additionally, some synthetic materials will support combustion and could be very dangerous around fire. One hundred percent cotton materials would be the minimum, cotton treated with a fire retardant would be better and fire proof materials like Nomex would be best.
- b. **Noise: Ear protection is recommended around the FireBox.** It is a good practice to wear approved ear protection when working in close proximity to the fan and engine.
- c. **Hot Panels:** The backs of the thermo-ceramic panels and parts of the steel structure can reach temperatures as high as 500°F (260°C). Caution should be taken to ensure operator and visitors do not come in contact with these hot areas.
- d. **Wood Ash and Dust will be released** during the FireBox operation, especially during firebox ash cleanout. Operators must wear appropriate Personal Protective Equipment (PPE) like suitable body suits, eye protection, gloves, boots, etc. and in particular face masks like respirators to keep ash that may be suspended in the air from entering their lungs. It must be understood that all persons near an operating FireBox must protect themselves from dust and wood ash as it may be harmful if wood ash and dust enters their airways which may result in injury or death.



Even with proper Personal Protective Equipment (PPE) a person must not step into a firebox without first removing all wood ash residues, embers and unburned feedstock; otherwise an accident may occur which may result in injury or death. There may be hot embers and hot coals hidden within the ash bed and wood ash may be suspended in the air from stirring up the ash bed. This may make it difficult to breathe.

### **PERSONAL PROTECTIVE EQUIPMENT (PPE) & WOOD ASH CAUTION:**

**Always wear appropriate Personal Protective Equipment (PPE) while working with the FireBox, especially a breathing apparatus like a respirator while removing wood ash from the firebox and while handling the wood ash.**

**DANGER: Operators must ensure debris does not build up on the front equipment deck. It must be kept clean at all times during operation to prevent a fire that would damage or destroy the engine and accessories which could result in injury or death to persons nearby.**

## HOW TO SET UP THE FIREBOX

### A. POSITIONING THE UNIT

The S-Series units are totally self-contained and ready to use upon delivery to the job site. The FireBox units are built on a skid base that is designed to facilitate dragging the unit into position and to move the unit around the site. The weights of the various units are given in the table on page 2. Ensure that lifting or tow cables are certified for these weights.

With respect to the prevailing wind direction, the unit should be positioned such that the wind comes over the back of the manifold. This is the preferred position. It is also acceptable to have the wind blow into the manifold. It is discouraged, however, to have the wind come from either end of the machine, as this will tend to disrupt the air curtain.

As highlighted under Safety Considerations on page 5, the FireBox must be placed on plain level ground (dirt), and it must not be placed on combustibles like dry grass or peat moss and also never on a concrete pad, gravel, crushed stones or asphalt.

### **DANGER:**

**When you tow (drag) the FireBox, especially in soft soil, watch that the dirt does not build up under the panels and lift the panels off the rails. That is why you must never walk inside the FireBox when it is being towed. A dislodged panel could fall on a person inside the firebox which will result in serious injury or death.**

**Typically, the softer soils will require a longer cable. If the rear of the unit sinks into soft soil while it is being towed, use another vehicle to follow and carry some of the load. If you are still having trouble dragging the unit, try a different length of tow cable. Always stay clear of the tow cable while the dragging operation is underway and wear Personal Protective Gear (PPE).**

### B. PRE-OPERATION CHECKS:

1. Air filter for cleanliness (VERY IMPORTANT).
2. Engine oil level.
3. Engine coolant level and antifreeze rating.
4. Diesel fuel level.

## HOW TO SET UP THE FIREBOX

### C. STARTING

**Note:**

The key can only be removed from the key switch in the OFF position. Turning the key left to the Auto position is not functional and is not used for your HATZ engine.

**This Machine is equipped with a “FLUID COUPLING” (Automatic Clutch). It will function automatically. The clutch will spin the air fan at idle which tends to make light up of the fire more difficult and the fire may even be blown out.**

**Therefore, the engine should be started and warmed up to ensure it is operational then shut down temporarily for the initial light up sequence.**



Electronic Control Panel  
(Lockable Cover Open)

### STARTING Engine

1. Turn key switch right to ON (1) position. The display will be activated.
2. Wait for automatic PREHEAT to complete.
3. Turn key to START, release, once engine is running.
4. Wait for speed to level off at 900 RPM (*Idle*).
5. Shut down engine by setting key switch to OFF position for light up sequence.
6. Turn key switch to START, release, once engine is running.
7. Wait for speed to level off at 900 RPM for *Idle*.
8. Press Throttle Button UP, wait for speed to level off at 1400 RPM.
9. Press Throttle Button UP again to set speed for **Operating Low:**

S327	2200 RPM
S330	2300 RPM

10. Press Throttle Button UP again to set speed for **Operating High:**

S327	2500 RPM
S330	2600 RPM



Throttle Button UP & DOWN

## HOW TO SET UP THE FIREBOX

### D. SHUT-DOWN

1. Turn key switch to OFF position. The air fan will free-wheel the fluid coupling and spin to stop. This will not cause any engine issues.

**WARNING:**

Call the Air Burners Customer Support Department for help if the Control Panel throws any fault codes. Call 772-220-7303 or 888-566-3900.



Electronic Control Panel  
(Lockable Cover Open)

**WARNING:**

Your HATZ Diesel Engine is an EPA Tier 4 FINAL certified computer controlled engine. Do not attempt to re-program the Electronic Control Module (ECM) by pressing buttons at random on the control panel. Contact Air Burners Customer Support Department for help, if any errors have occurred.

Call 772-220-7303 or 888-566-3900.

Note: The engine does not require DEF.



Throttle Button UP & DOWN

## SITE PREPARATION

### THE GOALS TO GOOD SITE PREPARATION ARE:

- To place the FireBox for easy access.
- To sort the waste wood pile.
- To organize the inflow of new wood waste.

When locating the FireBox, consider access for your truck and trailer to load and unload the FireBox. Ensure there is enough room to maneuver your truck and trailer.

Consider where the waste piles will be located. We generally recommend two waste piles (explained in the next section).

Consider the predominate wind direction. Hot embers will be escaping from the FireBox during all burning operations.

Consider where and how you will empty the wood ash from the firebox. If you are going to 'drag' the FireBox to empty it, ensure there is room and the soil conditions are not too soft. If you are going to excavate the wood ash out, then consider where you will dump it. In most cases cold wood ash can be reapplied to the land. Check your local ordinances.

Once the FireBox is in position, it is important to place dirt around the inside bottom of the firebox (burn chamber) to close any openings under the skids that may be caused by uneven terrain as shown on [page 4](#). This will prevent smoke and heat from escaping. Pay particular attention to the seal for the forward (engine deck side) wall. Any openings under the panels or forward skid will allow heat from the fire to reach the area below the engine deck. This could cause the engine deck to become hot enough to burn the paint and be a hazard to someone standing on the deck.

**DANGER:** Never dig a pit in the center of the firebox. This will make it hard to seal the inside of the firebox and the walls of the pit can deteriorate during operation allowing smoke and heat to escape from the firebox or reach the area below the engine deck creating a serious hazard for anyone standing on the deck. This will also void your Air Burners Limited Factory Warranty.

**DANGER:** Never place the FireBox on combustibles like peat moss or dry grass, and never position it on a concrete pad, gravel or crushed stones or asphalt. For more details, see [Page 7](#).

**DANGER:** This machine DOES NOT prevent hot embers from escaping. This machine is designed primarily as a pollution control device to reduce the smoke generated from open burning clean wood waste and to reduce the wood waste efficiently.



## SITE PREPARATION

### Faster operation through staging the wood piles

Air Burners FireBoxes were designed primarily as a pollution control device, but operated correctly they will burn clean wood significantly faster than open burning. To achieve the best throughput, the fire must remain at the highest temperature possible. You achieve this by remembering three rules:

1. Don't smother the fire with a huge load or a load of very dense material.
2. Load "less more often", that is smaller bucket loads more often.
3. Sort out a pile of your best burnable wood, use it to create a hot fire.

The basic principle of operation is not too different from a campfire. You use your best wood to get it started, and if the fire dies down you add some more "Good Wood" to bring it back up. The big difference is that on your campfire you are probably not adding root balls or branches with leaves or pine needles. These are the high moisture content and dense materials that bring the fire temperature down.

The temperature drops (smoke increases) and your burn rate slows down, if you overload the machine with materials that have high moisture content, such as tree branches with leaves and needles, or green branches such as palm fronds. While these are certainly acceptable to burn in the FireBox, you want to add them to a hot fire so they dry out and ignite quickly.

To keep the temperature up and to maintain the highest throughput of feedstock, you should mix the very burnable wood with the less burnable materials throughout the course of the burning operation. The most common way to accomplish this is to stage a pile of the most burnable materials or what we call the "Two Pile System."



S220 FireBox Loading Over Manifold

***"If it's burning clean it's burning hot; if there is smoke, you're losing money."***

## **SITE PREPARATION**

### **The “Two Pile System”**

For an efficient operation you would have two piles:

The **first pile** or “Main Debris” Pile, is the material being generated from the land clearing or forest clearing operation or otherwise collected and is located away from the ember path, but with good access to your loading machinery.

The **second pile** or “Good Wood” Pile is your best and most burnable wood. When you first setup the site, the operator should spend some time sorting through the main debris pile pulling out what appears to be your best, most burnable feedstock. This is the material with which you will start the fire and this material will give you a good hot burning base fire. You will also draw from the “Good Wood” pile throughout the day if you should need to stoke up the fire (more on this in the following sections).

As the FireBox operator is drawing from the main wood debris pile throughout the day, he or she should continue to replenish the “Good Wood” pile as necessary. The “Good Wood” pile only needs to be enough material to stoke-up the fire if needed and enough material to get you started the next day if a “Hot Start” is contemplated.

### **IMPORTANT WARNING ABOUT BURNING OF PALLETS:**

**Wooden Pallets, especially spent pallets, burn extremely hot. DO NOT load the machine above approximately 3/4 of the height of the firebox (burn chamber). Heat damage to the manifold and other structure may occur which would not be covered under your Limited Factory Warranty.**

### **DANGER:**

**You must ensure debris does not build up on the equipment front deck. It must be kept clean at all times during operation to prevent a fire that would damage or destroy the engine and accessories and may cause an accident resulting in injury or death to persons standing on the deck.**

## LOADING AND STARTING THE FIREBOX

### LOADING THE FIREBOX

You can load the FireBox from either side, but we recommend loading from the manifold side because (1) it is safest and (2) it tends to increase the life of the manifold, as it reduces the chance for it to be accidentally damaged.



### THE GOALS IN STARTING A FIREBOX ARE:

1. To achieve an even fire across the length of the firebox.
2. To start the fire from the bottom of the initial load of wood waste.
3. To build a hot base fire.

There are two methods for lighting the unit: a *cold start* and a *hot start*. A cold start means the FireBox is clean and has no hot coals left from a previous burn. A hot start uses heat from the coals of the previous day's burn.

### COLD START

1. The unit should be on level ground and the engine should be off, as the fluid clutch would spin the air fan which would make it more difficult to light the fire and the fire may even be blown out. Ensure, though that you have started the Diesel engine and warmed it up before switching it off for the light up.
2. To prevent smoke from escaping under the firebox, shovel dirt along the inside bottom edges of the panels. It will only need a couple inches to prevent the smoke from escaping underneath the unit. This is generally only a concern on hard ground, and it usually only lasts for the first hour of burning. After burning for a while the ash will build up and seal off the bottom of the firebox.
3. Load your most burnable material (materials from the "Good Wood" pile as discussed in the previous section) which is the smaller, dryer and cleaner wood, into the firebox to a level about half way up. Ensure that the entire bottom area of the firebox (burn chamber) is covered.
4. If you are permitted to use diesel fuel to assist in the lighting, spray it (approx. 10 gal.) across the top of this first load of wood. Be sure to get some diesel fuel on the wood near the lighting holes in the firebox side and on the wood towards the back. This will help make it easier to light.

**DANGER: If you are using an accelerant, first ensure there are NO HOT COALS remaining in the firebox.**

**DANGER: DO NOT use highly volatile accelerants such as gasoline or kerosene, to light the fire. These fluids ignite almost explosively and may cause injury or death.**

## LOADING AND STARTING THE FIREBOX

### Overview

7. Once you have the smaller material loaded and your accelerant added (if used), load some larger, heavier feedstock on top such as logs or big branches. Load these heavier materials (also from your “Good Wood” pile) to a height just below the manifold nozzles or approx.  $\frac{3}{4}$  height for machines burning pallets. This heavier material will help compress the smaller material which will give you a better light-off. If there are large air spaces between the wood debris in the firebox the heat will not build up as quickly and the fire may be more difficult to light.
8. Once burning this material will become your hot base fire to support continued burning. Use your best and driest materials (“Good Wood”) for startup as this will form a strong base for continued burning, plus it will start quicker and burn hotter. If you will be burning stumps, it is best to load them after the first hour of burning when the fire is up to full temperature.
8. The level of material in the firebox for light-off should be kept just below the manifold nozzles, except for units burning pallets which should only be loaded up to approximately  $\frac{3}{4}$  of the firebox height. Pallets burn extremely hot and loading them to a higher level would tend to warp or destroy the manifold. This heat damage would not be covered by your Limited Factory Warranty.
9. If you are allowed to use diesel fuel as an igniter, it is sometimes helpful to add a second coat to the top load again. ENSURE THERE ARE NO HOT COALS REMAINING IN THE UNIT before adding the accelerant.
10. Your goal is to develop a good hot base fire and to maintain a good hot fire throughout your burning operation. This will give you the cleanest burn and the most throughput.
11. There is always smoke on start-up as all of the material in the firebox contains moisture, compared to later in the burn operation when only the new material you are loading contains moisture. Plus, the air curtain cannot be fully engaged until the fire has strengthened, or you run the risk of blowing out the fire.

### **IMPORTANT WARNING ABOUT BURNING OF PALLETS:**

**Wooden Pallets, especially spent pallets, burn extremely hot. DO NOT load the FireBox above approximately 3/4 of the height of the burn chamber. Heat damage to the manifold and other structure may occur which would not be covered under your Limited Factory Warranty.**

### **DANGER:**

**NEVER stand on the FireBox like on the front deck roof, air fan or the upper rails, as falling into the firebox will cause a serious accident resulting in injury or death.**

## LOADING AND STARTING THE FIREBOX

To minimize start-up smoke you can:

Use your driest wood waste materials.

Ensure your feedstock has no embedded dirt or sand.

Use diesel fuel to accelerate the light up, if permitted.

### **COLD START LIGHTING**

1. The engine must be switched off to keep the fluid clutch from rotating the fan, but engine warmed up.
2. For best results and quickest light up, start the fire from the bottom because fire will spread upwards much better than it will spread downwards.
3. Use a propane torch (like a weed burner) or oil soaked rags on poles (where allowed) to light the fire.
4. The fire must be started from the access doors in the panels on the manifold side of the unit.



Access Door for Lighting

If you are allowed to use diesel fuel as a starter, let the fire burn until you begin to see wisps of white smoke replacing the wisps of black smoke from the diesel fuel or, if you are using propane torches, wait until the fire has strengthened and flames are reaching the top of the firebox. Then turn on the engine again and set the engine at 1400 RPM. As the fire burns stronger, increase the air up to maximum engine RPM.

Do not increase the air too quickly as you can “blow” the fire out. If you add air and the smoke gets heavier, then reduce the RPM and let the fire “catch-up.” Once the smoke clears up you can increase the air again.

Sometimes it is helpful to “fan” the fire during the start-up phase. You accomplish this by increasing the RPM for 3 to 8 minutes, then decreasing it (i.e. 1400 RPM up to 2500 RPM (S327) or 2600 RPM (S330) and back down to 1400 RPM). This sometimes helps to spread the fire throughout the material. How much air to add and when to add it during startup will vary with the type of materials being burned.

## **LOADING AND STARTING THE FIREBOX**

### **HOT START**

A hot start uses the coals from the previous day's burning operation. Depending on how much ash is in the unit, a hot start can be done once or twice before the unit must be emptied. The more ash in the firebox with which you start, the LESS room you have for burning new wood waste materials.

First, ensure there are enough coals remaining to generate enough heat to get the new wood waste materials burning. You CANNOT and MUST NOT add an accelerant, if the waste materials do not light as that would be too dangerous. You can use propane torches in the lighting holes if you have trouble with a hot start. If the material does not light, the firebox must be emptied completely before trying a cold start with the use of an accelerant.

### **DANGER:**

**Do not use any kind of accelerant for a Hot Start, as it may ignite unexpectedly and cause an accident resulting in injury or death.**

### **HOT START LIGHTING**

Similarly to a cold start you begin with your best and most burnable materials.

1. Load the firebox to about one third or half way with the feedstock from the "Good Wood" pile. The wood should begin burning as soon as you start loading.
2. Set the air fan at 1400 RPM. This should help fan the flames and spread the fire. If you experience heavy smoke then reduce the RPM. Be cautious not to "blow out" the fire.
3. As the fire begins to heat up, increase the RPM.

### **DANGER:**

**NEVER stand on the FireBox like on the front deck roof, air fan or the upper rails, as falling off the machine or into the firebox will cause a serious accident resulting in injury or death.**

## HOW TO FEED A FIRE

It will generally take approximately 30 minutes for the fire to build to a point where the temperatures are sufficient for the unit to be operating with minimal smoke.

1. Add material from your “Good Wood” pile slowly for the first hour. It takes about an hour for the fire to reach minimum temperature. Your goal is to achieve an even and hot fire across the unit.
2. For continuous operation the engine RPM is run at full throttle (preset at the factory). If the fire is burning very hot with no smoke the RPM can be reduced to save diesel fuel, but that is very dependent on the waste material.
3. If you get excessive smoke and ash when you load the wood waste while dropping the load through the air curtain, then you may need to turn the RPM down temporarily as you load. This is most likely earlier in the burn operation.
4. Take caution when loading the unit that the material to be burned is not “dumped” into the firebox too quickly causing hot embers to be thrown from the unit.
5. If you have an area in the firebox that is smoking, this indicates the temperature is low in that area. Add material from the “Good Wood” pile to get the fire temperature up. Once that area is burning, add some of the heavier feedstock.
6. The rate at which you load the unit varies depending on moisture content of the wood waste and the temperature of the fire. If you overload the firebox you will notice an increase in white smoke. White smoke is an indication that the temperature is dropping. If the smoke increases stop loading until the fire has caught up. You can also bring the temperature up by adding materials from the “Good Wood” pile.
7. For the highest throughput, load “*LESS MORE OFTEN.*” Smaller loads more often will give the materials a better chance to ignite and will result in your highest throughput of wood waste. Oversized bucket loads may smother the fire for a short period before they ignite; this will slow the burning down and reduce your daily throughput.
8. The load in the firebox should not go higher than the bottom of the manifold (except only approximately  $\frac{3}{4}$  firebox height for machines burning pallets). If the material is piled higher, it will begin to break the air curtain and more smoke will escape. This likely will also violate your permit.
9. The fire should be loaded continuously throughout the day, in order to maintain operating temperatures. If the fire is not loaded continuously, the temperature will drop, the throughput will go down and more smoke will escape.

***“If it’s burning clean it’s burning hot; if there is smoke, you’re losing money.”***

## SHUTDOWN

### HOW TO BURN THE FIRE DOWN FOR SHUTDOWN

All loading should stop one or two hours before you intend to put the fire out.

As the fire burns down, maintain the air speed until the firebox begins to smoke. As the smoke increases, reduce the air speed. This will help to reduce the smoke.

The air in the manifold needs air flow, both to accelerate the burn down and to protect the manifold from warping due to excessive heat. **DO NOT shut off the engine (air flow) while there are still flames within 24 in. of the manifold.** Doing so may cause elevated temperatures to warp the manifold, nozzle assembly, etc. Your warranty does NOT cover damage due to excessive heat.

Once the fire has burned down to about one or two feet and flames are not visible near the manifold, it will be safe to shut down the engine and thereby the air by turning the key switch to the OFF position. Make sure the fire is extinguished before you leave the job site. The best way to ensure this is to load dirt or sand into the firebox, **but do not spray the refractory walls with water as this will damage them** (except in a dire emergency).

Some local authorities allow the FireBox to be secured and the embers to smolder all night. There is generally no smoke from this smoldering. Ensure the work site is secured or has a constant security guard to prevent any persons or animals from getting near the FireBox. The inside temperatures of the unit will remain very high most of the night.

If you are not allowed to smolder through the night, then verify the fire inside the firebox is completely out. If it is still burning or smoldering you can either drag the FireBox forward and water down the ash and embers left behind, or you can use sand or dirt to cover the remaining hot spots inside the firebox. **Do not spray the refractory walls with water as this will damage them.** Ensure the fire is completely out and the job site secure before you leave.

### **DANGER:**

### **NEVER CLIMB ON THE FIREBOX TO VIEW OR LIGHT THE FIRE**

**Use the ladder built into the FireBox and firmly grasp the provided handle. Never step beyond the top rung. If you use a step ladder or similar platform, locate at a safe distance from the FireBox. Do not stand along the rails or on top of the FireBox (like the front deck roof or air fan) under any circumstance.**

**Falling into the FireBox or from the FireBox will cause an accident resulting in serious injury or death.**

**All persons must always wear suitable Personal Protective Equipment (PPE) while near an operating FireBox and during ash clean out and ash handling.**



## ASH REMOVAL

### HOW TO EMPTY THE FIREBOX

We recommend removing the ash every morning before burning operations begin. This will give you maximum capacity in the firebox and the ash will be easier to handle.

The firebox will operate with up to 3 ft. of ash inside, but as the ash gets deeper the efficiency of the unit goes down. Three feet of ash would represent approximately 20 hours of burning. The FireBox should not be run with over 3 ft. of ash inside.

There is only one way to empty the ash out of the electrically powered FireBox, namely, by excavating it out best with an Air Burners ash rake but an excavator could also be used.

### ASH RAKE

Air Burners offers an ash removal implement (ash rake) as pictured to the right. It has been designed for each model FireBox. The ash rake is fitted with a universal quick connect faceplate or a blank faceplate for installation on your unique machine (weld it yourself).

You can remove some or all of the ash by reaching in through the rear doors with the ash rake dragging the ash out. **Remember to use**

**Personal Protective Equipment (PPE) including a breathing apparatus (i.e., a respirator), otherwise an accident may occur resulting in injury or death. Be also cautious of the remaining hot embers in the ash bed.**



It is not required to remove all the ash, if you are planning on a hot restart, generally just a scoop or two with the ash rake is all that is required. This will leave a very hot ember base

**DANGER:** Ash and dust will be released during the FireBox operation, especially during firebox ash cleanout. Operators must wear appropriate Personal Protective Equipment (PPE) like suitable body suits, eye protection, gloves, boots, etc. and in particular face masks like respirators to keep ash that may be suspended in the air from entering their lungs. It must be understood that all persons near the FireBox must protect themselves from dust and ash as it may be harmful if wood ash and dust enters their airways which may result in injury or death.

Even with proper PPE a person must not step into a firebox without first removing all wood ash residues, embers and unburned feedstock, otherwise an accident may occur which may result in injury or death. There may be hot embers and hot coals hidden within the ash bed and wood ash may be suspended in the air from stirring up the ash bed. This may make it difficult to breathe.

## **ASH REMOVAL**

### **HOW TO EMPTY THE STANDARD FIREBOX**

#### **2. EXCAVATING**

Excavating the ash out is a common method for daily operations as it allow you to maintain the ember base for restarting a new day's burning operations.

You can remove some or all of the ash by reaching in through the rear doors with an excavator or ash rake and scooping the ash out. **Remember to use an appropriate breathing apparatus like a respirator and other Personal Protective Equipment (PPE) as appropriate, and be cautious of the remaining hot embers.** It is not required to remove all the ash if you are planning on a restart, generally just one "scoop" or two is all that is required. This will leave a very hot ember base from which you begin the new day with a "hot start" as explained previously.

#### **DANGER:**

**When removing wood ash from the FireBox, be aware of the wind direction and ensure all operators and lookers-on wear appropriate breathing apparatuses like respirators to prevent inhaling any airborne wood ash and other appropriate Personal protective Equipment (PPE)., otherwise an accident may occur that may result in injury or death.**

#### **3. DRAGGING**

Dragging the unit will allow you to remove all the wood ash for repositioning or when a job is complete, but it will not allow you to maintain the embers for a "hot start."

Open the back doors and cover the wood ash with a thin layer of dirt to minimize ash getting airborne. Connect appropriate strength and length cables or chains to the pad eyes or the pull block on the front of the machine and pull the FireBox forward. The ash will pile up and fall out the back of the unit. Be cautious for the remaining hot embers. Wet the ash pile down, remove unburned chunks of wood and then mix the ash into the native soil or otherwise dispose of it as required by local ordinance.

#### **DANGER:**

**When removing wood ashes from the firebox, make sure that no hot ashes, embers, burning or hot materials are carried by the wind to places where they could start a fire!**

## **TROUBLESHOOTING**

### **1. Fire will not start.**

Material in firebox has too much air space. To correct, load heavy material such as stumps to make the lower material pack down. Use torches and light from the bottom so the fire burns up.

### **2. Fire burning at one end.**

Load heavy materials directly on top of the burning area. This causes the flames to fan out in an effort to reach the top of the pile. As the fire begins to spread, keep material piled on top of the flames until the feedstock in the entire firebox is burning.

### **3. Fire smoking too much.**

The most common reason for a smoking fire is too much dirt or dense materials going into the firebox and reducing the heat. You must make sure the wood waste material is free from large amounts of dirt and stones. Load from your “Good Wood” pile to bring the temperature back up.

You may have overloaded the firebox or loaded the firebox too fast. Example: if you only have one ton of material burning you cannot load three tons of material on top of it. The new material will smother the fire. Stop loading and let the fire catch up. The material you are loading may have a very high moisture content. You can either load at a slower rate or mix the wetter material with dryer material.

If you are letting the fire burn down or the wood waste pile in the firebox is less than 3 ft. deep you may need to turn the air down by reducing the engine RPM.

### **4. Smoke from one area of the firebox.**

That area is probably not burning well. Add smaller material from your “Good Wood” pile to this area to help build the fire. As the smoke clears add heavier material.

### **5. Smoke from under the base rails or bottom of panels.**

Loose dirt was not properly shoveled around inside of firebox to seal between panel bottoms and the ground. To fix this, shovel dirt around the outside where the smoke is escaping. Once the ash inside builds up this will stop.

## **DANGER**

**You must ensure debris does not build up on the equipment front deck. It must be kept clean at all times during operation to prevent a fire that would damage or destroy the engine and accessories and could cause an accident resulting in injury or death.**



## 100 Series Air Curtain Burner with HATZ 4H50 Diesel Engine & Fluid Coupling OPERATING MANUAL

### MAINTENANCE AND CARE

#### **WARNING:**

Should any repairs become necessary that require welding on your FireBox, you **MUST** first physically remove the Electronic Control Module (ECM) from the computer controlled Diesel engine. Follow the instructions on the inside cover page ([Page i](#)) of this Operating Manual.

**MAINTENANCE AND CARE:** See Page 25 and Appendix B for additional details. Consult the supplied HATZ Engine Service Manual and the MBW Electronic Control Panel Manual.

#### 1. Daily Check List:

- a. Oil level (top off as needed).
- b. Engine coolant level (top off as needed).
- c. Diesel fuel level in fuel tank.
- d. Tap dirt out of air intake housing and check for excessive dirt.
- e. Clean debris off radiator.
- f. Check for fluid leaks.

#### 2. Periodic Maintenance

- a. Change oil and oil filter.
- b. Replace fuel filters as needed (Main filter, pre-filter, Racor water separation filter).  
**NOTE:** FireBoxes shipped from the factory after November 20, 2023 have been fitted with HATZ engines where the pre-and main fuel filters are combined into a single unit (see Appendix B).
- c. Grease both (inside and outside) air fan bearings every 2-4 months  
(Do NOT over grease).
- d. Grease fluid clutch bearing every 120 hrs. (Approx. 4-5 grease gun pumps or 10 g).  
Call factory for major service every two (2) years.
- e. Inspect adjustment of coupler hubs and realign by re-adjusting the engine isolators (“motor mounts”) as needed. For instructions see Appendix A
- f. Check alternator V-belt and adjust as needed.
- g. Arrange for service of fluid coupling with Air Burners Technical Support (every 2 years or as needed).

**The HATZ Diesel Engine does not require DEF.**

**Contact Air Burners, Inc., should you require assistance with any of these necessary maintenance tasks. Send Email to [support@airburners.com](mailto:support@airburners.com), call 772-220-7303 or 888-566-3900 (Customer Support).**

## **THERMAL-CERAMIC PATCHING COMPOUND**

**FOR MINOR REPAIR OF AIR BURNERS REFRACTORY PANELS AND DOORS.**

**Air Burners Part # 6900-1003 “Thermal-Ceramic Wet Pre-Mix”**

*NOTE: This is an air cured product. Reseal unused portion immediately.  
Once opened the shelf life is one (1) year.*

### **Directions:**

1. Cracking of the panels is normal as they flex in the heat. Filling the cracks every 6 months or as needed will extend the life of your Thermal-Ceramic Panels.
2. Air Burners patching compound is pre-mixed and ready to use (may require some stirring).
3. Storage: Compound should be stored indoors in a frost-free location.
4. Preparation: the area in and around the damaged area to be patched must be cleaned and brushed to provide the best surface for the compound to adhere. Remove all loose refractory and debris from the area to be patched.
5. Wet the cleaned surface with a light spray or damp cloth.
6. Installation: Using a trowel or similar tool, pack the refractory compound material into cracks and into areas where the refractory is missing. To achieve proper thickness, trim off the excess material using a sharp, flat blade or the side of the trowel.
7. Allow the material to harden overnight before placing the FireBox back into service. After the compound has hardened, operate the FireBox under normal conditions.

**NOTE:**  
*This is an air cured product. Reseal unused portion immediately.*

### **WEAR PERSONAL PROTECTIVE EQUIPMENT (PPE):**

**Always wear appropriate Personal Protective Equipment (PPE) while working with the thermal ceramic patching compound repairing the refractory panels or while performing any other maintenance task on your FireBox.**



**100 Series Air Curtain Burner with HATZ 4H50 Diesel Engine & Fluid Coupling  
OPERATING MANUAL**

**Parts List for Routine Service of**

**HATZ 4H50TIC and 3H50TIC Industrial Diesel Engine (Tier 4F)**

Refer to Appendix B “Engine Overview” and the HATZ Service Manual for Additional Engine Service Details

(Engine must be serviced after first 50 hours, then every 500 hours of operation or as needed)

Description	Air Burners P/N	Manufacturer’s P/N	Service Interval
Air Filter (Main Element H50)	5000-2338	HATZ 50638200	500 Hours
Air Filter (Secondary Element H50)	5000-2339	HATZ 50638300	500 Hours
Oil Filter H50	5000-2340	HATZ 50638800	500 Hours
Oil Separator H50 (Crank Case Vent)	5000-2341	HATZ 50640500	500 Hours
Fuel Filter H50	5000-2342	HATZ 50638100	500 Hours
Pre-Fuel Filter	5000-2343	HATZ 50638000	500 Hours
Combo Main & Pre-Fuel Filter*	5000-3007	HATZ 2147501	500 Hours
Poly-V-Belt (Engine) H50	5000-2344	HATZ 50629401	500 Hours
Fuel/Water Separator Filter	5000-1297	RACOR R20P	As needed
Battery, 12V, Max 120Ah; Max. CCA 800; Min. CCA 750; RC 130	5000-2472	Interstate Batteries 24M-XHD	As needed

\* Applies only to HATZ engines shipped after November 20, 2023.

Diesel Fuel	Ultra Low Sulfur Fuel Only (ULSD)
Engine Oil	10W40 or 15W40 Diesel Grade
Engine Oil Capacity	4H50: 7.2 qt. (6.8 L)
Engine Radiator Protection Fluid *	Coolant Fluid must be approved by HATZ, i.e. Havoline XLC (OF02), Havoline XLC+B, Castrol Radicool SF, Exxon Mobil Delvac ELC Coolant
Bearing Lubricant	NLGI Grade 2
DEF and DPF **	Not required (Engine meets US EPA Tier 4 Final and EU 97/68 Stage 3 B)
Fuel Tank Capacity	Minimum 110 gal. (416 L)

**Consult FireBox Operating Manual for engine-to-air fan coupler service and adjustment.**

\* Contact Air Burners Customer Service Dept. for complete list of HATZ approved Radiator Protection Fluids.

\*\* DEF = Diesel Exhaust Fluid      DPF= Diesel Particulate Filter

**Contact Air Burners, Inc., should you require assistance with any maintenance task.  
Email: [support@airburners.com](mailto:support@airburners.com)  
Phone: 772-220-7303 or 888-566-3900  
(Customer Support)**

## LIFTING POINTS & STAIR GUARD

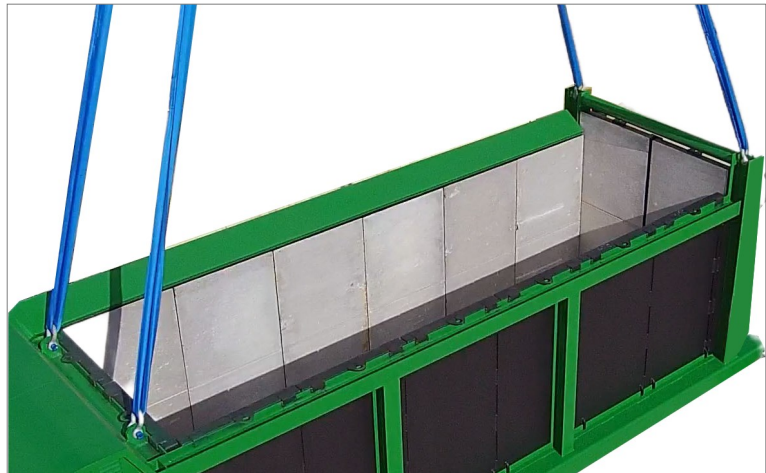

### **WARNING:**

There are four designated lifting pad eyes for lifting all FireBox units by crane, two on each side. **Only lift by attaching straps or cables to these four pad eyes.** Their locations are marked with yellow lifting point labels with *up-arrows*).

### **WARNING:**

The Stair Guard is shipped in place secured with a bolt and nut (red circle in photo to right). The bolt should be replaced with a suitable padlock, before the FireBox is placed into service.

Only authorized personal must be allowed to remove the stair guard and persons wearing suitable Personal Protective Equipment (PPE) using the built-in stairs must hold firmly onto the handle and never step beyond the top rung.

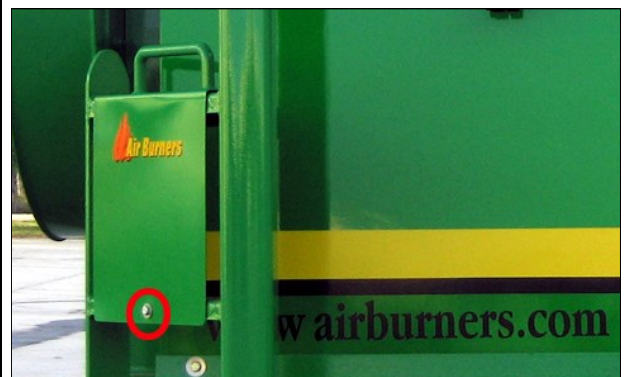

## APPENDIX A CHECKING COUPLING ALIGNMENT

This Technical Memorandum covers FireBox Models equipped with Dodge Raptor Couplings. The S327 and S330 FireBoxes use Size E30 (Air Burners Replacement Part Number 5000-2120) and all other FireBox models use Size E20 (Air Burners Replacement Part Number 5000-5123). Certain FireBoxes equipped with electric motors (mostly 300 Series) are also fitted with Dodge Raptor couplings. The general coupling information in this Technical Memorandum applies to them also.

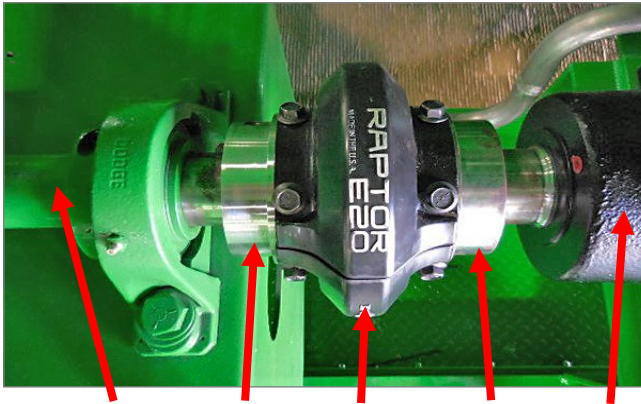

**FAN SHAFT HUB    ELEMENT    HUB    FLUID CLUTCH**

The coupling shown above is an E20 with the protective guard removed

### TOOLS REQUIRED

Coupling hubs should be aligned using straight edges or calipers. Laser alignment tools, or other precision alignment equipment can be used but are not required.

#### Tools

1. Two open-end wrenches, 3/4"
2. Torque wrench
3. Sockets/wrenches, 9/16" & 7/16"
4. Straight Edge Ruler or Calipers

**WEAR SUITABLE PERSONAL PROTECTIVE EQUIPMENT (PPE).**

### Step 1 Preparation

1. Lock out engine/motor to prevent accidental start which could cause injury.
2. Remove the protective metal guard (Not shown in image above) from fan.
3. Take off the element by removing the Grade A bolts holding the two halves together. Bolts should be used only one time. All bolts use thread locking patches.
4. If any coupling adjustments are required, be prepared to realign the engine by adjusting the four engine isolators until the measurements of Steps 2, 3 and 4 are achieved.

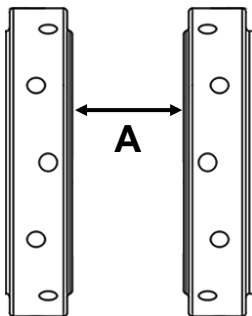

### Step 2 Verify Gap Between Hubs

1. Measure the distance "A" between the hubs with calipers or other appropriate tool.
2. If needed, set distance "A" as follows:

GAP MEASUREMENT "A"		
E20	2.46"	62mm
E30	2.55"	65mm



## APPENDIX A CHECKING COUPLING ALIGNMENT

### Step 3 Verify Angular Alignment of Hubs

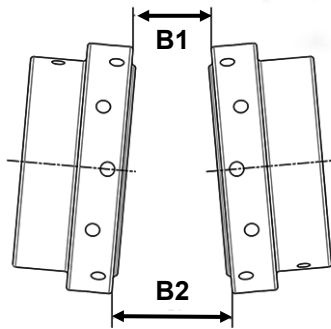

$C=B2-B1$

1. Measure the distance “B” between the hubs with calipers or other appropriate tool at four places on the outer diameter of the hub 90° apart.
2. Use the “B2” and “B1 ” measurements to calculate “C” by subtracting the smaller measurement from the larger number, and do this for each of the 90° apart planes .
3. Adjust the engine isolators until the “C” measurements of both planes do not exceed these Angular Values:

ANGULAR VALUE “C”		
E20	0.235”	6mm
E30	0.284”	7.2mm

### Step 4 Verify Parallel Alignment of Hubs

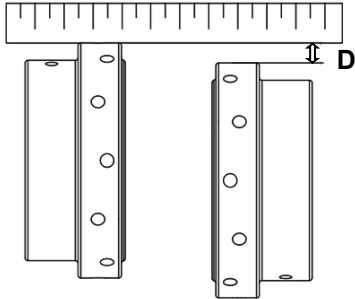

**D** is the distance between straight edge and lower outer hub edge

1. Check parallel misalignment by placing a straight edge across the outside diameter of the hubs and measuring the gap between the straight edge and the hub at four locations 90° apart.
2. Adjust the engine isolators until the “D” measurements do not exceed these Parallel Values.

PARALLEL VALUE “D”		
E20	0.188”	4.8mm
E30	0.188”	4.8mm

### Step 5 Element Installation

1. Place first element half on hubs and hand-tighten the flange head bolts. When tightening the bolts, start at the center bolt hole and then install the bolts on the neighboring holes.
2. Place the second half of the element on the hubs and follow the same procedure. Hand-tighten the flange head bolts.
3. Use a torque wrench to tighten all fasteners for the E20 and E30 to these torque values (same for both):

ELEMENT BOLT TORQUE VALUES				
	Bolt Size	In-lbs.	ft-lbs.	Nm
E20 & E30	3/8	502	42	57

**APPENDIX B  
HATZ ENGINE OVERVIEW (4H50)**

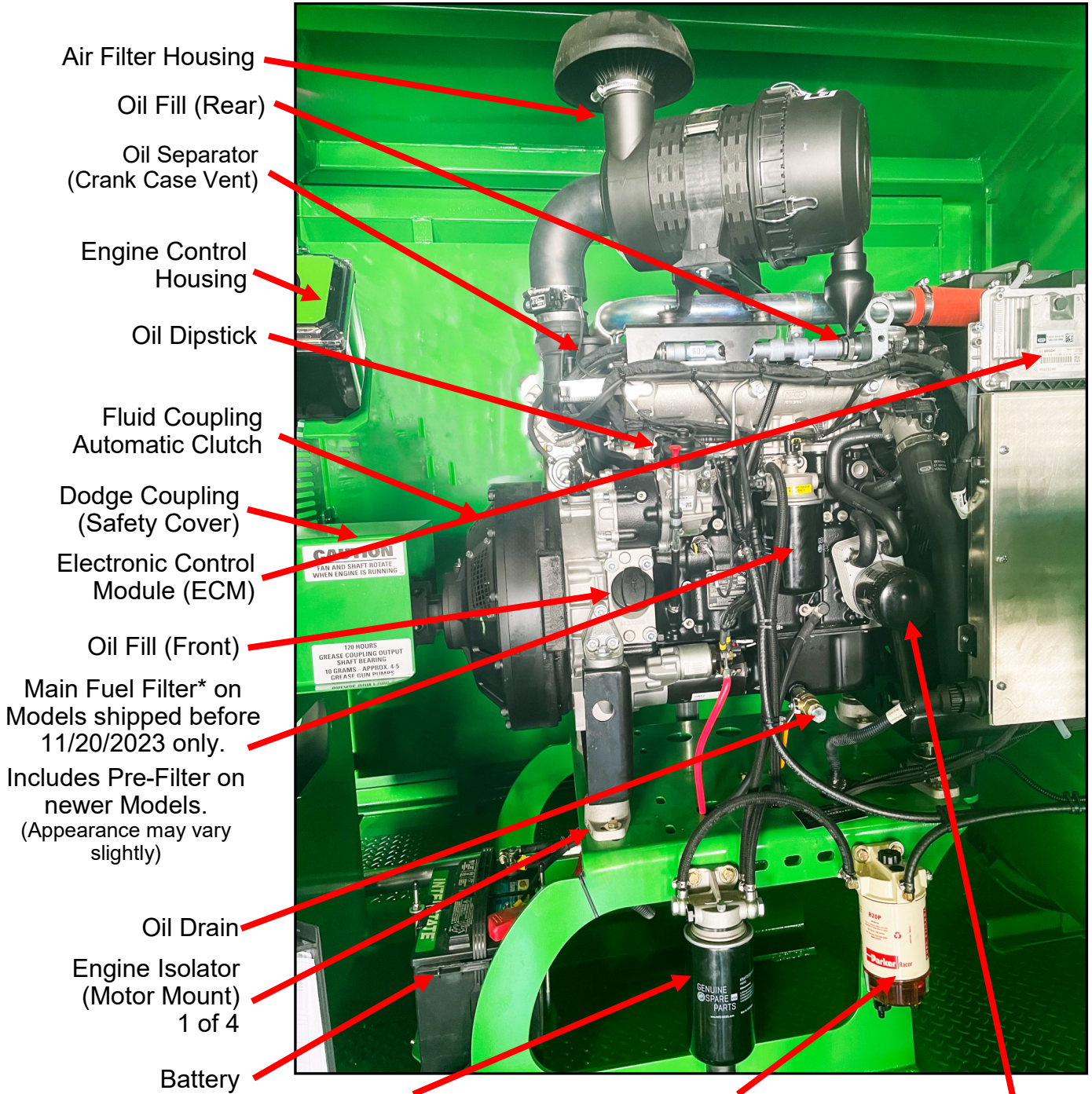

Main Fuel Filter\* on Models shipped before 11/20/2023 only. Includes Pre-Filter on newer Models. (Appearance may vary slightly)

\*Pre-Fuel Filter - only on Models shipped before 11/20/2023

RACOR Fuel-Water Separator

Oil Filter

**NOTE:** On FireBoxes shipped after November 20, 2023, the HATZ Diesel engine fuel filter system was simplified by combining the main filter and pre-filter into a single unit.