

Operating Manual

T26 CharBoss®



“Better Economically - Better Environmentally”
MADE IN THE USA

Factory and Main Office
Air Burners, Inc.
4390 SW Cargo Way
Palm City, FL 34990

Phone: 772-220-7303
888-566-3900
E-mail: support@airburners.com

Visit Our Website at
[AirBurners.com](https://www.AirBurners.com)



© 2024 Air Burners, Inc. All Rights Reserved.
Subject to change without notice. Dimensions & metric conversions rounded. The words *Air Burners*, *BurnBoss*, *CharBoss*, *TrackBoss*, *BioCharger* and the *Air Burners Logos* are Registered Trademarks of Air Burners, Inc.

Caution

The T26 CHARBOSS[®] as “Trailer-Mounted Machinery” is “Non-Self-Propelled Agricultural/Forestry Equipment”

The triple axle T26 CharBoss Biochar Processor is street legal. Its GVWR is 17,500 lb. (7940 kg). A Class 5 Commercial Duty Hitch on the towing vehicle is required (Ball Size 2-5/16 in. or 58.75 mm). Familiarity with all state and local trailer towing regulations and ordinances is advised.

Before traveling on public roadways, check functionality of towing vehicle’s brake controller and hitch and on T26 CharBoss trailer check ball coupler, safety chains, break-away system, self-adjusting electric brakes, wheels, tires and trailer lighting. Ensure the T26 CharBoss Travel Safety Pins on the two hydraulic actuators are properly in place and secured.

After a burn event, make sure there is no burning debris trapped anywhere in the T26 CharBoss, especially no hot embers, before moving the machine away from the burn site.

The firebox (burn chamber) of the T26 CharBoss radiates considerable heat downwards and may drop hot embers. The firebox must be lowered onto level earthen ground (dirt) and never onto combustibles like dry grass or peat moss and the machine must also not be operated on a surface like a concrete pad, gravel, crushed stone or asphalt (See Page 6 for more details).

Always wear Personal Protective Equipment (PPE) when working with or around the T26 CharBoss and especially when handling the residual wood ash. Be mindful of Pinch Point Hazards. Keep your hands clear from all moving parts and hot parts of the T26 CharBoss while it is in operation.

CAUTION

Please, read and understand all Caution and Warning Notices and Operating Instructions before working with the T26 CharBoss and always follow them diligently. Disregarding these important Notices may lead to an accident that may result in property damage and a person’s injury or death.

Contact Air Burners, Inc. Customer Service should you require any assistance. Send to Email to support@airburners.com, call 772-220-7303 or 888-566-3900.

WELDING REPAIR WARNING:

Should any welding repairs become necessary on your T26 CharBoss, you **MUST** first physically remove the Electronic Control Module (ECM) from the computer controlled Diesel engine. Follow the instructions below. If you need help, call Customer Support at 772-220-7303 or 888-566-3900.

**HATZ DIESEL ENGINE 3H50T****ECM Removal Steps**

1. Wear Personal Protective Equipment (PPE).
2. Ensure engine is switched off and cold.
3. Disconnect negative battery cable.
4. Unsnap Latches 1 and 2.
5. Remove Bolts A1 and A2.
6. Unplug both connectors.
7. Remove Bolts B1, B2, B3 and B4.
8. Remove the two brackets.
9. The ECM can now be removed and stored away while repairs are made.
10. Re-install all in reverse order.

PERSONAL PROTECTIVE EQUIPMENT (PPE) & WOOD ASH CAUTION

Always wear appropriate Personal Protective Equipment (PPE) while working with the T26 CharBoss, especially a breathing apparatus like a respirator while removing wood ash from the T26 CharBoss and while handling the wood ash and biochar. [See Page 8.](#)

WARNING:

Watch for, read, and understand the **DANGER NOTICES** you will find throughout this operating manual. Failure to heed the **notices** may result in an accident causing **serious personal injury or death.**

INDEX

WELDING REPAIR WARNING.....	Page ii
PRINCIPLE OF AIR CURTAIN INCINERATION	Page 1
GENERAL DESCRIPTION OF THE T26 CharBoss	Page 2
MAIN COMPONENTS OF THE T26 CharBoss	Page 4
SAFETY CONSIDERATIONS	Page 6
HOW TO TRANSPORT THE T26 CharBoss	Page 9
HOW TO SET UP THE MACHINE	Page 12
SITE PREPARATION	Page 16
LOADING AND STARTING THE T26 CharBoss	Page 19
OPERATING THE T26 CharBoss	Page 22
HOW TO FEED A FIRE	Page 24
SHUTDOWN	Page 25
ASH REMOVAL	Page 26
T26 CHARBOSS TROUBLESHOOTING	Page 27
MAINTENANCE, CARE AND SAFETY CHECKS	Page 29
ADJUSTING CONVEYOR BELT STATIC TENSION	Page 31
THERMAL CERAMIC PATCHING COMPOUND	Page 32
SERVICING SPECIFICATIONS	Page 33
APPENDIX Page 1 TRAILER WIRING SCHEMATICS	Page 34
APPENDIX Page 3 LIFTING POINTS AND D-RING TIE DOWNS....	Page 34
APPENDIX Page 4 HATZ DIESEL ENGINE 3H50T OVERVIEW	Page 34



T26 CharBoss (2024 Build PO9)

PRINCIPLE OF AIR CURTAIN INCINERATION

OPERATION

Air curtain burners are designed primarily as a pollution control device to make open pile burning cleanest. Using a Diesel engine driven fan, these machines generate a curtain of air with a very particular mass flow and velocity. This curtain of air acts as a trap over the top of a thermal ceramic lined firebox like the T26 CharBoss. The wood debris is dumped into the firebox (burn chamber) and then ignited (usually with a propane torch and with a small amount of diesel fuel where permitted) just as you would light any other pile of wood you intended to burn. Once the fire has gained strength, the air curtain is turned on. The air curtain traps most of the smoke particles and causes them to re-burn directly under the air curtain where the temperatures exceed 1800° F. These machines do not inject any fuels into the fire, the fire is sustained only by adding more wood debris. The air from the air curtain is not heated. The only fuel used in the continuous operation is that of the Diesel engine driven fan.

The same air curtain pollution control principle is also built into the T26 CharBoss, however, it has been designed with special features to process the wood waste into biochar rather than completely eliminating it by burning it into residual ashes. Biochar is a byproduct in the residuals of all our air curtain burners and it has become a very desirable natural product. The simple to operate trailer mounted T26 CharBoss processes forest slash or other clean wood waste into commercially viable quantities of biochar. It is ideally suited for on-site operation in forests i.e., for fuels management.

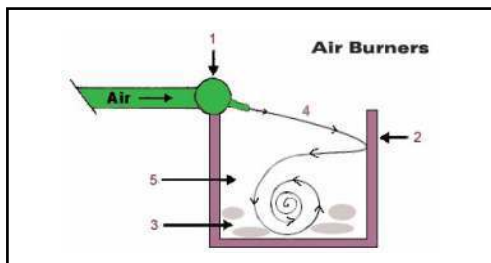

“The Wood Waste is the Fuel”

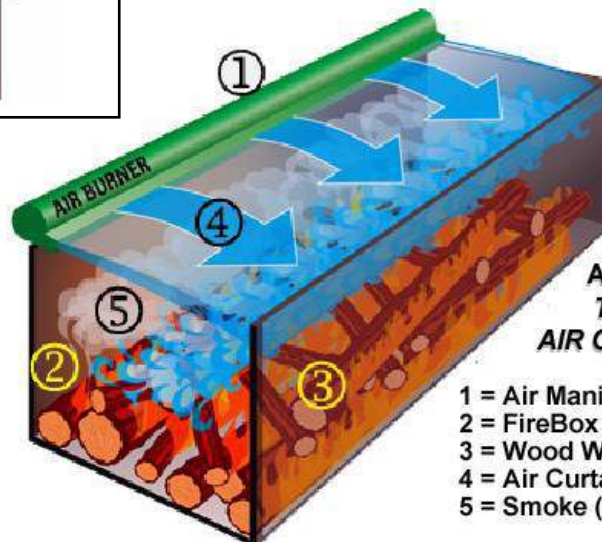

**AIR BURNERS, INC.
THE PRINCIPLE OF
AIR CURTAIN BURNING**

- 1 = Air Manifold
- 2 = FireBox Refractory Wall
- 3 = Wood Waste or Wood Fuel
- 4 = Air Curtain (left to right)
- 5 = Smoke (PM or Black Carbon)



[Click Here](#) or Scan
for Video
“Open Pile Burning
vs FireBox Burning”

GENERAL DESCRIPTION OF THE T26 CHARBOSS

The T26 CharBoss design is intended to allow for the use of our self-contained refractory walled air curtain system design. The T26 CharBoss is mounted on a trailer frame for ease of mobility and biochar processing instead of total wood waste elimination. Most of the functions and principles for the T26 CharBoss are the same as the standard T24 BurnBoss, except for the design features that process wood waste into biochar. The T24 BurnBoss has been designed strictly for the efficient reduction of wood waste and not for enhanced biochar processing. The self-propelled T28 TrackBoss is similar to the T24 BurnBoss, with the trailer frame replaced by a remotely controlled track system (Photo lower right). The standard S-Series FireBox machines are offered in several sizes as indicated below.

Above-Ground Air Curtain Burner Dimensions					
Model	Overall Size L x W x H	Firebox L x W x H	Weight lbs.	Fuel gal/hr.	Average Thru-put* tons/hr.
S330	40' 4" x 11' 10" x 9' 6"	30' 2" x 8' 5" x 8' 1"	59,000	3.0	11-13
S327	37' 4" x 11' 10" x 9' 6"	27' 2" x 8' 5" x 8' 1"	54,600	3.0	9-11
S223	33' 3" x 8' 6" x 8' 6"	22' 11" x 6' 2" x 7' 1"	40,250	2.0	7-9
S220	30' 1" x 8' 6" x 8' 6"	19' 8" x 6' 2" x 7' 1"	36,650	2.0	5-7
S119	27' 3" x 7' 2" x 7' 4"	19 x 5' x 6'	30,100	1.9	3-5
S119R**	27' 6" x 7' 2" x 8' 3"	19 x 5' x 6'	39,900	1.9	3-5
S116	24' 7" x 7' 2" x 7' 4"	16' x 5' x 6'	27,500	1.9	2-4
S116R**	24' 11" x 7' 2" x 8' 3"	16' x 5' x 6'	36,300	1.9	2-4
T24	19' 8" x 7' 8" x 5' 8"	12' x 4' x 4'	9,980	0.56	½-1
T26	21' 8" x 7' 8" x 6' 8"	12' x 4' x 4'	17,500	1.1	½-1
T28	17' 10" x 8' 5" x 5' 8"	12' x 4' x 4'	15,350	1.1	½-1

* Approximate values. Achievable through-put depends on nature of waste stream and other factors.

** Cable-hoist version; Hook-lift version is 5" shorter



Standard FireBox S220



T28 TrackBoss (Remote Control)

GENERAL DESCRIPTION OF T26 CHARBOSS

The T26 CharBoss is a design that adds not only mobility but biochar processing to the Air Burners FireBox line of machines, in particular to the popular T24 BurnBoss. When delivered to a job site, the machine is ready for use as soon as it is off-loaded. The firebox system is built on a patented trailer frame that allows the firebox to be raised and lowered for easy movement over the ground. The firebox is lined with proprietary thermal-ceramic refractory panels. The panels are cured prior to installation at the factory to drive out any moisture to ensure they are stable at first use in the field. The forward equipment deck under the cowling supports a three-cylinder Diesel engine, a 20-gallon fuel tank, the direct drive system and the air fan. In addition the battery and firebox hydraulic controls are located here. When viewed from the rear of the unit, the patented air disbursement manifold is mounted on the right top side of the combustion chamber of the firebox.

The Diesel engine is directly coupled to the main air fan. The high velocity air is sent down the manifold through the vanes and directed to the outlet nozzles. A balanced and distributed air flow is directed across the top of the firebox and then reflected down into the combustion zone.

The curtain of air acts as a top over the firebox, trapping a large percentage of the escaping particulate matter (smoke) and causing it to burn down even further under the curtain before finally escaping through the air curtain as a hot gas. The air from the nozzles travels across the firebox creating the air curtain effect, then it reflects off the far side thermal ceramic wall adding oxygen to the combustion zone helping to generate a hotter more complete fire. This additional agitation helps prevent the fire from starving for oxygen as the ash builds up during burning operations.

The T26 CharBoss incorporates most of the design features as the T24 BurnBoss. However the T26 CharBoss includes a hydraulically driven mechanical grid and transport design to facilitate biochar processing as opposed to optimizing the rapid reduction of woody debris featured by the T24 BurnBoss. That is accomplished by limiting the residence time of the burning char in the firebox. A shaking panel agitates the woody waste material as it is being combusted. This forces small chunks of hot coals to fall onto a continuously moving belt system, which in turn transports the hot glowing particle chunks to the rear of the machine. They are then released into a collection tray filled with water for the quenching of the biochar.

The biochar as a finished product is periodically collected from the quenching tray. This is a manual operation on the current T26 CharBoss model. To conserve water, which is a precious commodity in the forest and agricultural fields, the T26 CharBoss design features a system that conserves water with minor water loss from evaporation.

MAIN COMPONENTS OF THE T26 CHARBOSS

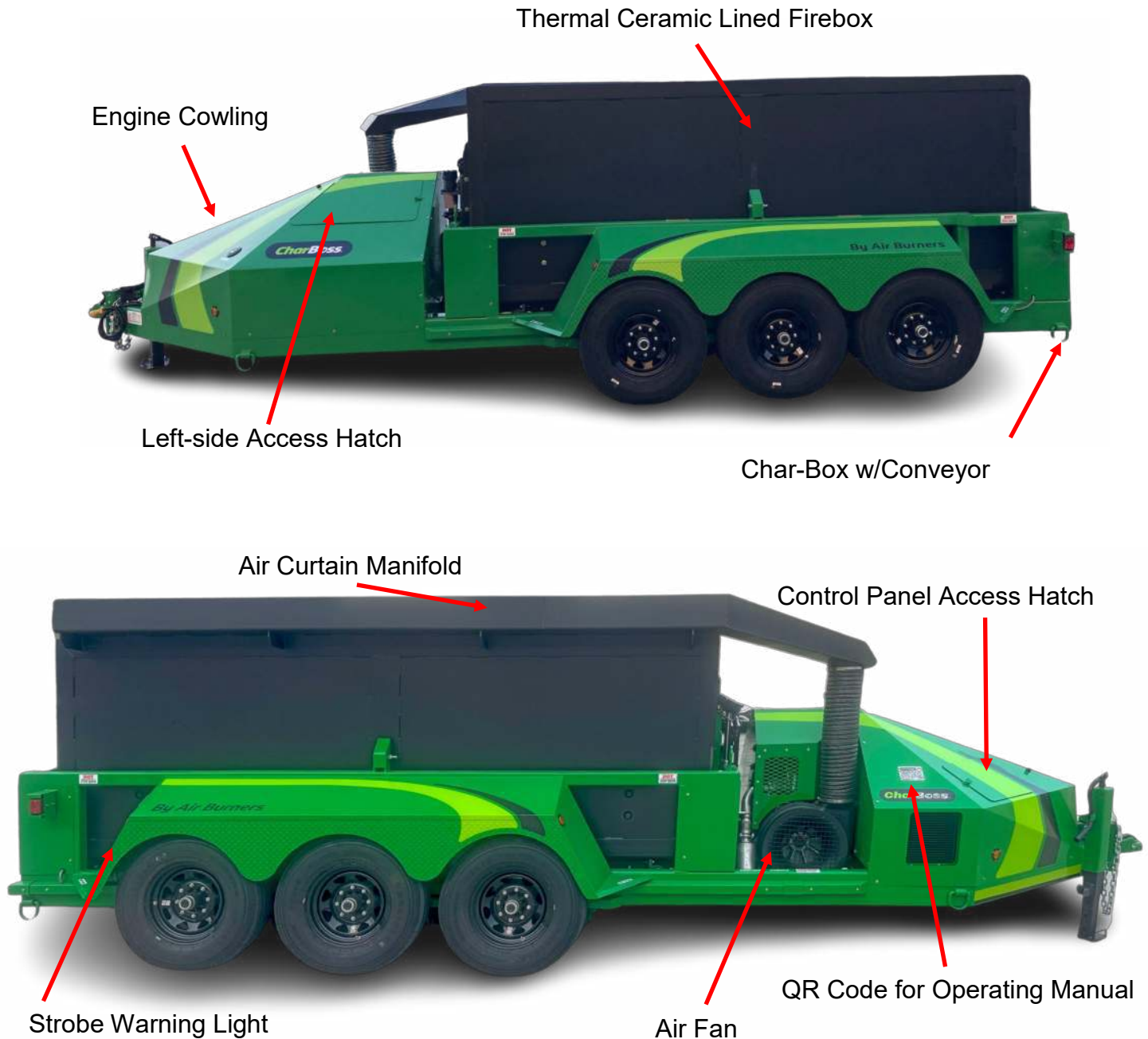

T26 CharBoss in Travel Mode with Firebox in Up Position.



T26 CharBoss in Operation

WARNING:

Watch for, read, and understand the **CAUTION** and **DANGER NOTICES** you will find throughout this operating manual. Failure to heed these warning notices may result in an accident causing property damage and **serious personal injury or death.**



T26 CharBoss Towable Air Curtain Burner for Biochar Processing (HATZ 3H50T Engine) OPERATING MANUAL

SAFETY CONSIDERATIONS

READ ALL SECTIONS OF THIS MANUAL BEFORE YOU BEGIN BURNING OPERATIONS

The T26 CharBoss operator is dealing with fire on a daily basis; it is very important that each and every individual involved with the machine be alert and practice very rigid safety precautions.

When you are running the T26 CharBoss you are responsible for ensuring that it is operated in the safest possible manner at all times. If you notice something wrong, correct it immediately, and if you cannot correct it, find someone who can and/or shut down the machine.

Basic Safety Points:

1. **The T26 CharBoss must be placed onto cleared, level ground.**

The T26 CharBoss should be driven onto level ground to facilitate loading, dumping and moving of the unit. When lowered, the firebox must touch the ground on all four sides or smoke and embers will escape.

2. **The unit should be positioned such that no combustible material is stored within a minimum 100 ft. clearance in any direction.**

The firebox (burn chamber) of the T26 CharBoss radiates considerable heat downwards and may drop hot embers. The firebox must be lowered onto level earthen ground (dirt) and never onto combustibles like dry grass or peat moss and the machine must also not be operated on a surface like a concrete pad, gravel, crushed stone or asphalt. There is a good reason for this warning. Concrete or gravel can contain water which the heat in an operating T26 CharBoss could vaporize quicker than it can be drawn out. This could result in increased vapor pressure that can cause the concrete or stones to explode. Fragments could possibly fly out of the firebox and cause injury or death to persons nearby.

In addition *hot embers* will escape from the unit and, depending on the wind, will land on the ground around the unit. The machine should not be located within 100 ft. of any stored combustible materials. The waste material to be burned during the day's operation can be staged within the 100 ft. perimeter to facilitate loading. The operator must monitor the loading pile to ensure embers do not ignite the loading pile. The combustible materials to be stored for burning at a later date must be stored outside the 100 ft. perimeter or in accordance with the chart on Page 7 of this manual which suggests adjustments for wind speed.

3. **The unit should not be operated when the wind speeds reach 20 mph, as the potential to carry hot embers is significantly increased.**

As an operator you should always be aware of wind speed and direction. Increased wind speed will affect the integrity of the "air curtain" and will cause hot embers to travel farther. See the wind speed chart regarding suggested set-backs on Page 7.

WARNING:

Watch for, read, and understand the CAUTION and DANGER NOTICES you will find throughout this operating manual. Failure to heed these warning notices may result in an accident causing property damage and serious personal injury or death.



**T26 CharBoss Towable Air Curtain Burner for Biochar Processing (HATZ 3H50T Engine)
OPERATING MANUAL**

- 4. **NEVER use highly combustible materials to light the wood waste.**
Highly combustible materials such as gasoline, refined spirits, etc. ignite at an explosive rate which may cause serious injury or death. The safest method to start the fire in the firebox is to use materials such as kindling wood. In the absence of these materials or when starting materials with a high moisture content, use diesel fuel as an acceptable option.
- 5. **NEVER climb onto the T26 CharBoss or lean over to view or light the fire.**
Always load and operate the machine from the MANIFOLD side.
Hot embers will escape at a low height opposite the manifold. The left side of the machine (opposite the manifold) must be restricted access to prevent injury to persons.
- 6. **Shut the T26 CharBoss down in an emergency.**
Stop loading the unit, stop the air flow by shutting down the engine. Dump dirt or sand onto the fire. Water should only be used as a last resort as it will tend to damage the hot refractory panels.

DANGER:
Falling into the T26 CharBoss will cause serious injury or death. DO NOT stand within 20 feet of the T26 CharBoss on the side opposite the manifold.

WIND SPEED VS. SAFE DISTANCE			
Wind Speed mph	Approximate Safe Distance for:		
	Structures (Houses, etc.) ft.	Woods/Trees ft.	Stored Brush Piles ft.
10	300	150	100
12	300	150	100
14	300	200	150
16	400	250	150
18	400	250	200
20	500	250	200

DANGER:
The above distances serve as a GUIDELINE ONLY! You MUST ALWAYS observe the down range area regardless of the wind speed. You must always observe local fire ordinances and directives from the local fire department or other competent authorities.

T26 CharBoss Towable Air Curtain Burner for Biochar Processing (HATZ 3H50T Engine) OPERATING MANUAL

7. Personal Safety (Personal Protective Equipment – PPE)

Operators need to be aware of the following potential hazards:

- a. **Flying hot embers being released from the fire:** Operators or anyone within the 100 ft. radius of the fire should wear appropriate fire resistant clothing. The ideal outerwear for an operator would include a Nomex jacket, leather gloves, eye protection, hard hat, cotton work jeans and steel toe boots. Operators should never wear synthetic material (i.e., polyester) around the fire as this type of material can melt and cause injury. Additionally, some synthetic materials will support combustion and could be very dangerous around fire. One hundred percent cotton materials would be the minimum, cotton treated with a fire retardant would be better and fire proof materials like Nomex would be best.
- b. **Noise - Ear protection is recommended around the T26 CharBoss:** It is a good practice to wear approved ear protection when working in close proximity to the fan and engine.
- c. **Hot Panels:** The backs of the thermal-ceramic panels and parts of the steel structure can reach temperatures as high as 500°F. Caution should be taken to ensure operator and visitors do not come in contact with these hot areas.
- d. **Wood ash and dust will be released** during the T26 CharBoss operation, especially during biochar collection and ash cleanout. Operators must wear appropriate Personal Protective Equipment (PPE) like suitable body suits, eye protection, gloves, boots, etc. and in particular face masks like respirators to keep ash that may be suspended in the air from entering their lungs. It must be understood that all persons near the T26 CharBoss must protect themselves from dust and wood ash as it may be harmful if wood ash and dust enters their airways which may result in injury or death.



Upon moving the T26 CharBoss briskly forward for ash cleanout, there may be hot embers and hot coals hidden within the ash bed left behind and wood ash may be suspended in the air from stirring up the ash bed. This may make it difficult to breathe. While handling hot biochar fumes may be released which could be harmful if they would enter a person's airways. Always wear appropriate Personal Protective Equipment (PPE) while handling the wood ash residue and biochar.

PERSONAL PROTECTIVE EQUIPMENT (PPE) & WOOD ASH CAUTION

Always wear appropriate Personal Protective Equipment (PPE) while working with the T26 CharBoss, especially a breathing apparatus like a respirator while removing biochar or wood ash from the machine and while handling the biochar and wood ash.

DANGER: You must ensure debris does not build up on the T26 CharBoss. It must be kept clean at all times during operation to prevent a fire that could damage or destroy the machine.

HOW TO TRANSPORT THE T26 CHARBOSS

A. Towing T26 CharBoss

The T26 CharBoss is considered street-legal “Trailer-Mounted Machinery” that is “Non-self-propelled Agricultural/Forestry/Construction Equipment”. The T26 CharBoss is equipped with self-adjusting electric brakes. They are properly adjusted at the Factory, but it is the operator’s responsibility to keep them adjusted by periodically backing up the T26 CharBoss while applying the brakes hard.



Towing the T26 CharBoss model is like towing any other “heavy” trailer. **It is important that the trailer frame rails are as level as possible** when hooked to the towing vehicle. If they are not level it will cause uneven loading between axles and may damage the suspension. The T26 CharBoss comes equipped with electric brakes on all six wheels. Be sure your truck has an appropriate “brake controller” that can handle a maximum current draw for the brakes of approximately 25 amps. The T26 CharBoss is also fitted with a break-away system. Check that the battery is charged, the breakaway safety cable and the pigtail with 7-blade RC receptacle are properly connected to the towing vehicle. This assures that the brakes and lights will function and the breakaway battery will be charged. Be sure your hitch assembly is rated for the towing weight of 17,500 lbs. (7940 kg) and a tongue weight of 1,650 lbs. (748 kg). Always maintain correct tire pressure to prevent premature wear and blow outs (see tire decal). Familiarize yourself with all state and local ordinances that apply to hauling a trailer of the weight of the T26 CharBoss on public roadways.

TOWING and TRUCK CONNECTION

1. The T26 CharBoss lower trailer frame rail **MUST** be level to the ground front to rear when connected to the towing vehicle.
2. The electrical “pigtail” connection must be correctly made (See Appendix for wiring schematics). Check the electric brakes and break-away system to make sure they operate properly.
3. The front jack stand must be up and secured.
4. Make sure the firebox travel safety pins on the front and rear actuators are properly in place and secured with their hitch pins for towing (**see Page 11**).
5. The safety chains and breakaway cable must be properly connected to the towing vehicle.
6. Test the brakes before you drive away.

DANGER: Do not transport the T26 CharBoss from the burn site until all fire and embers have been extinguished. **Caution:** Trapped embers may not be easily visible.

DANGER: You must ensure combustible debris does not build up on the equipment. It must be kept clean at all times during operation to prevent a possible fire that would damage or destroy the machine.

HOW TO TRANSPORT THE MACHINE

B. LOWERING THE FIREBOX FOR USE (SET-UP)

1. The T26 CharBoss firebox must be on level ground.
2. The machine must be disconnected from the tow vehicle.
3. The front jack stand must be down and secure.
4. **START ENGINE (See Page 14 for details).**
5. Operate with engine at IDLE – 900 RPM.
6. Switch HYDRAULICS to on.
7. Remove front and rear travel pins.
Note: If firebox is resting on travel pins and they cannot be easily removed, briefly press FIREBOX Switch to UP position to release weight off pin and remove same.
8. Hold FIREBOX Switch in DOWN position until firebox is lowered to the ground.
(See Page 14 for details)
9. Release FIREBOX switch.
10. Switch HYDRAULICS OFF.
11. Turn Engine off.
12. Perform Daily Maintenance (See Page 13).
13. Shovel dirt around the outside edges where the firebox contacts the ground to prevent heat and smoke from leaking out, especially behind the tires.
14. Locate Collection Tray for biochar output
15. Fill Collection Tray with water.



Jack Stand & Break-Away Unit

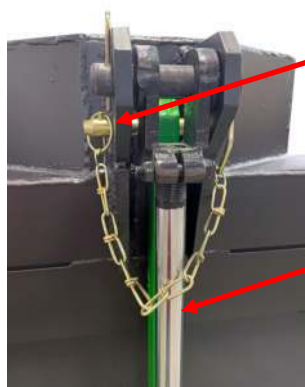

Travel Pin Installed

Travel Safety Pin

Hitch Pin

Actuator



Hitch Pin Attached to Chain

Hydraulic Oil

If you are operating in cold weather you may need to warm the hydraulic oil before use. In most cases running the engine briefly will generate enough heat. If you still have difficulties operating the hydraulic system you will need to change the oil to a colder spec oil (lower viscosity).

The hydraulic system comes standard from the factory with Amsoil Synthetic Hydraulic Oil ISO32 (Amsoil P/N HVH05-EA). If your machine will operate in cold temperatures or remain outside for long periods in cold temperatures you may need to use a synthetic hydraulic oil such as Amsoil P/N HVG05-EA, ISO22

C. RAISING THE FIREBOX FOR TRANSPORT

DANGER: Never transport the T26 CharBoss away from the burn site until you can ensure that all fires and embers have been completely extinguished. **Caution:** Look for trapped embers which may not be easily visible.

1. Connect machine to tow vehicle.
2. Raise jack stand.
3. Raise the firebox until it stops following these steps:
 - a. START ENGINE (See Page 14 for details).
 - b. Operate with Engine at MED – 2100 RPM.
 - c. Press Button 1 – RABBIT.
 - d. Repeat until Engine is running at MED – 2100 RPM.
 - e. Switch HYDRAULICS to ON.
 - f. Hold FIREBOX Switch in UP position until firebox is raised.
 - g. Release FIREBOX Switch.
 - h. Raise or lower to align Travel Lock Holes for Travel Pins.
 - i. Install and secure Front and Rear Travel Pins.
 - j. Switch HYDRAULICS to OFF.
 - k. Press Button 2 – TURTLE to decrease Fan Speed.
4. Turn Engine Off.
5. **Immediately** move the machine forward to prevent tire damage by hot embers on the ground.
6. Make all safety chain and truck-to-machine electrical connections (as applicable).
7. Ensure you have read the section on “TOWING” (Page 9) prior to entering public roadways.



Jack Stand & Break-Away Unit



Safety Pin Installed



Safety Pin Lock

DANGER: NEVER tow the machine without the safety pins properly installed as the hydraulic actuators may bleed down dropping the firebox on the road surface which may result in an accident causing injury or death.



The T26 CharBoss Ball Hitch Trailer Coupler is auto-latching (“Demco eZ-Latch” Mechanism Coupler). The height of the Channel Mount Receiver shown to the left is adjustable and the ball receiver can be replaced with an optional Pintle Hitch (MIL Hitch) available from our Parts Department.

Safety Pin for Hitch

HOW TO SET UP THE MACHINE

A. POSITIONING THE UNIT

The T26 CharBoss unit is self-contained and ready to use upon delivery to the job site.

1. The T26 CharBoss must be setup on level ground.
2. The firebox is lowered to the ground using the hydraulic controls (**See Page 13**).
3. The bottom edges of the firebox must touch the ground to ensure smoke and embers will not escape underneath the firebox walls. If necessary shovel some dirt against the walls from outside the firebox to seal the edges. This must be done prior to loading the firebox with feedstock. Add dirt around the bottom behind the tires to help prevent any heat from damaging the tires.
4. With respect to the prevailing wind direction, the unit should be positioned such that the wind comes over the back of the manifold. This is the preferred position. It is also acceptable to have the wind blow into the manifold. It is discouraged, however, to have the wind come from either end of the machine, as this will tend to disrupt the air curtain.
5. The firebox will be loaded either by hand or by machine, like a Bobcat, always **OVER THE MANIFOLD**. The firebox should not be loaded opposite the manifold as there are many hot embers in this area making it dangerous for personnel.
6. Secure the area (use orange safety cones, signs, fencing, etc.) opposite the manifold (20' x 20' - see diagram below) and along the side of the machine to ensure persons do not get near the hot fire or embers or the rear biochar chute and quenching Device.

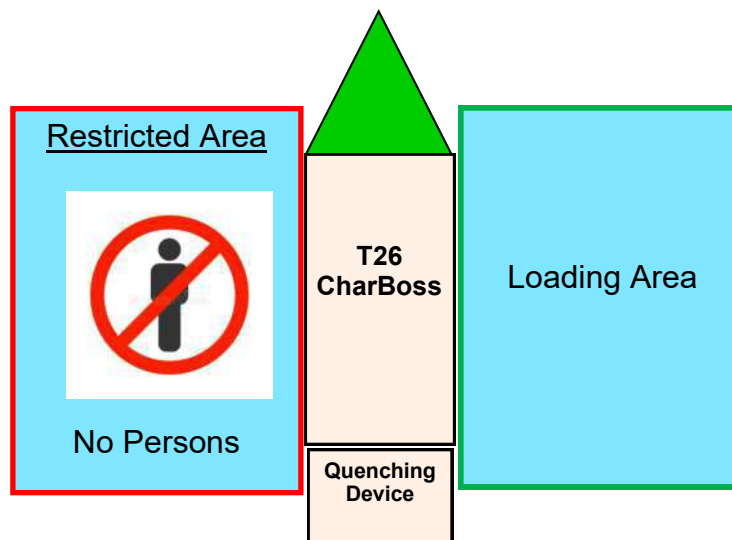

DANGER: Always load the T26 CharBoss from the right side over the manifold to prevent any flying hot embers from endangering personnel.

**T26 CharBoss Towable Air Curtain Burner for Biochar Processing (HATZ 3H50T Engine)
OPERATING MANUAL**

B. PRE-OPERATION CHECK LIST:

1. Air filter for cleanliness (VERY IMPORTANT).
2. Engine oil level and hydraulic oil levels.
3. Engine coolant level and antifreeze rating.
4. Diesel fuel level.
5. Battery cable.
6. Check hydraulic lines.

Upper Service Access Hatch
Cowling: Diesel Fuel Fill & Upper: Air Filter, Dip Stick, Hydraulic Oil & Coolant Reservoirs



Upper Service Access & Diesel Fuel Fill

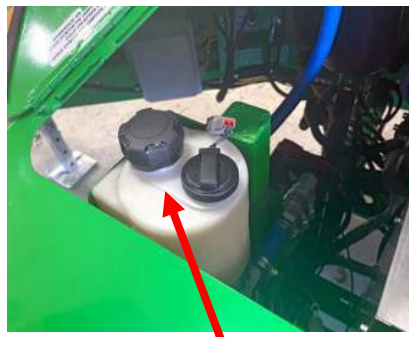

Hydraulic Oil Reservoir

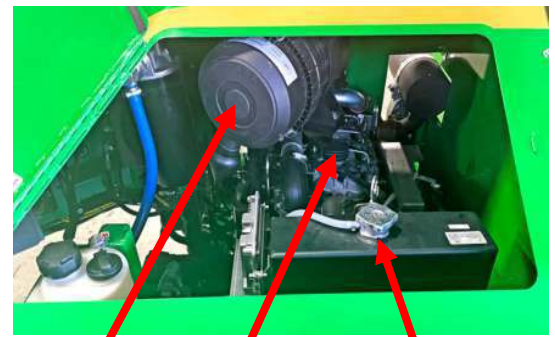

Air Filter Engine Oil Fill Coolant Filler



Detailed View of Main Control Panel with Legible Instrument and Switch Captions

HOW TO SET UP THE MACHINE

C. STARTING ENGINE (HATZ 3H50T Diesel Engine)

1. Set all switches to OFF position.
2. Press any button on Engine Controller to power up.
3. Press “ENGINE START – STOP” Button for ENTER PIN to appear.
4. Use Buttons 1, 2, and 3 to enter your PIN.
5. The Engine Controller will read READY TO START.
6. Press “ENGINE START – STOP” Button to start engine.
7. Wait for engine to level off at IDLE - 900 RPM.

Once running, the engine speed may be varied as required by pressing Buttons 1 or 2, respectively on the Engine Controller.



Control Panel Hatch & Operating Instructions



**Control Panel with Toggle Switches & Gauges
(See Page 13 for Enlarged Image)**



Engine Controller

The maximum engine speed is governed to assure the correct amount of air flow.

HOW TO SET UP THE MACHINE

D. SHUTTING DOWN ENGINE (HATZ 3H50T Diesel Engine)

1. Set all switches to OFF position.
2. Press Button 2 – TURTLE to Decrease Engine Speed
3. Repeat until Engine is Running at IDLE – 900 RPM
4. Press “ENGINE START – STOP” Button to Stop Engine



Engine Controller



Control Panel Hatch & Operating Instructions



Control Panel with Toggle Switches
& Gauges
(See Page 13 for Enlarged Image)

CAUTION:

Always wear appropriate Personal Protective Equipment (PPE) while near the T26 CharBoss and be mindful of Pinch Point Hazards; keep your hands clear from all moving parts and hot parts of the T26 CharBoss while it is in operation and cooling down at the end of the work shift.

SITE PREPARATION

THE GOALS TO GOOD SITE PREPARATION ARE:

To place the T26 CharBoss for easy access.

To sort the waste wood pile.

To organize the inflow of new wood waste.

When positioning the T26 CharBoss:

1. Consider access for your delivery truck and trailer to load and unload the T26 CharBoss, if not pulled by a pickup truck to the location. Ensure there is enough room to maneuver your truck and trailer.
2. Consider where the waste piles will be located. We generally recommend two waste piles (explained in next section).
3. Consider the predominate wind direction. Hot embers **will be** escaping from the firebox during all biochar processing operations.
4. Consider clearances for unit to be raised and towed **forward** until all the ash remains behind. When emptying, the tires must not come in contact with the hot embers or they will be damaged.
5. Consider clearances to collect and temporarily store biochar collected from the quenching tray and to clean the machine at the end of the workday
6. Once the firebox is in position, it is important to place dirt around the outside bottom of the firebox where the thermal-ceramic panels meet the ground to “seal” the bottom. This will prevent heat from escaping. Pay particular attention to the seal between the tires and firebox and between the front wall and engine bay.

DANGER:

Ensure your biomass feedstock does not include foreign objects like metal rods, wires, stakes or rocks. They may get lodged into the firebox panels and conveyor system and may cause significant damage to the machine.

DANGER:

This machine DOES NOT prevent hot embers and some particulate matter (smoke) from escaping. Wear Personal Protective Equipment while operating the T26 CharBoss.

SITE PREPARATION

Faster operation through staging the wood piles

Air Burners air curtain burners were designed primarily as a pollution control device but operated correctly they will burn clean wood two or three times faster than open burning. Additionally, the T26 CharBoss has been designed to process wood waste like forest slash to biochar. To achieve the best throughput and maximum biochar output the fire must remain at the highest temperature possible. You achieve this by remembering three rules:

1. Don't smother the fire with a huge load or a load of very dense material (like palm fronds), material that does not yield good hot coals as woody feedstock would.
2. Load "less more often" that is, smaller bucket loads more often.
3. Sort out a pile of your best burnable wood ("Good Wood Pile"), use it to create a hot fire.

The basic principle of operation is not too different from a campfire. You use your best wood to get it started and if the fire dies down you add some more "Good Wood" to bring it back up.

The temperature drops (smoke increases) and your burn rate slows down, if you overload the machine with materials that have high moisture content such as tree branches with leaves and needles, or green branches such as palm fronds. While these are certainly ok to burn in the T26 CharBoss if you must get rid of them add them to a hot fire, so they dry out and ignite quickly. Use your "Good Wood" to increase the temperature if necessary.

To keep the temperature up and to maintain the highest throughput of waste, you should mix the very burnable wood with the less burnable materials throughout the course of the burning operation. The most common way to accomplish this is to stage a pile of the most burnable materials or what we call the "two pile system."



T26 CharBoss in Travel Mode

SITE PREPARATION

The “Two Pile System”

For an efficient operation you would have two piles:

The **first pile** or “Main Debris” pile, is the material being generated from the land clearing or forest clearing operation and is located away from the ember path but with good access for loading.

The **second pile** or “Good Wood” pile is your best and most burnable wood. When you first setup the site the operator should spend some time sorting through the main debris pile pulling out what appears to be your best and most burnable materials. This is the material with which you will start the fire. This is the material that will give you a good hot burning base fire. You will also draw from the “Good Wood” pile throughout the day if you should need to stoke up the fire (more on this in the following sections).

As the T26 CharBoss operator is drawing from the main debris pile throughout the day the operator should continue to replenish the “Good Wood” pile as necessary. The “Good Wood” pile only needs to be enough material to stoke-up the fire if needed and enough material to get you started the next day.

IMPORTANT WARNING ABOUT BURNING OF PALLETS

Wooden Pallets contain steel nails and other fasteners that can jam the conveyor mechanism and must therefore not be used as feedstock for the CharBoss. Damage to the machine from introducing metal components and other foreign objects is not covered under your Limited Factory Warranty.

DANGER: You must ensure debris does not build up on the T26 CharBoss. It must be kept clean at all times during operation to prevent a fire that would damage or destroy the engine and accessories.

DANGER: You must ensure ash and other debris does not build up under the conveyor. It is necessary to move the machine every two days to prevent excessive buildup. If that is not possible, raise the firebox and remove the ash from beneath the conveyor. Before raising the firebox for ash removal, ensure that there are no embedded hot embers or coals in the ashes that could damage the wheels, tires and axles of the T26 CharBoss.

DANGER: When removing ash from the firebox by way of towing the T26 CharBoss machine forward, do so swiftly as soon as the firebox is raised to prevent any hot embers from damaging the wheels, tires and axles.



T26 CharBoss Towable Air Curtain Burner for Biochar Processing (HATZ 3H50T Engine) OPERATING MANUAL

LOADING AND STARTING THE T26 CHARBOSS

THE GOALS IN STARTING A T26 CHARBOSS FIRE ARE:

- To achieve an even fire across the length of the firebox.
- To start the fire from the bottom of the initial pile.
- To build a hot base fire.

1. Unit must be on level ground.
2. The Engine should be off, (but as described on Page 14 the engine should have been brought up to operating temperature).
3. Shovel dirt along the outside bottom edges of the panels to “seal” them. It will only need a couple inches to prevent the smoke from escaping underneath the unit.
4. Load the firebox from the side of the air manifold. This is safer as there is less chance of the operator coming in contact with hot embers.
5. Load your most burnable material (materials from the “Good Wood” pile as discussed in the previous section) which is the smaller, dryer and cleaner wood (also called “fines”), into the firebox to a level of about half way up. Ensure the entire bottom area of the firebox is covered.
6. If you are using diesel fuel to assist in the lighting, spray it (approximately 3 gallons) across the top of this first load of wood.

DANGER:

If you are using a suitable accelerant (like diesel fuel where permitted), first ensure there are NO HOT COALS in the firebox from an aborted startup or previous burn event.

DANGER:

NEVER use highly volatile accelerants, such as gasoline or kerosene, to help light the fire. Fluids like these ignite almost explosively and may cause injury or death.

LOADING AND STARTING THE T26 CHARBOSS (continued)

CAUTION: Do not 'pack' the biomass feedstock into the firebox by pushing it down with the bucket or rake of a loader like an excavator, as this will damage the shaker panels and conveyor belt assembly.

7. Once you have this smaller material loaded and your accelerant added (if used) load some larger heavier material on top, such as logs or big branches. Load these heavier materials, also from your "Good Wood" pile, to a height just below the manifold nozzles. This heavier material will help compress the smaller material which will give you a better light-off. If there are large air spaces between the materials in the firebox, the heat will not build up as quickly and the fire may be more difficult to light.
8. This material, once burning, will become your hot base fire to support continued burning. Use your best and driest materials ("Good Wood") for startup, as this will form a strong base for continued burning plus it will start quicker and burn hotter. If you will be burning stumps then it is best to load them after the first hour of burning when the fire is up to full temperature.
9. The level of material in the firebox for light-off should be kept just below the manifold nozzles.
10. Use an appropriate method such as a propane torch (like a weed burner) or diesel fuel soaked rags on poles to light the fire.
11. Once the fire is burning, start the engine (**See Page 14**) then follow these steps:
 - a. Change Engine RPM to adjust Fan Speed for fire conditions.
 - b. Controller has 4 RPM Setpoints.
 - c. Press Button 1 – RABBIT to increase Fan Speed.
 - d. Press Button 2 – TURTLE to decrease Fan Speed.
 - e. IDLE – 900 RPM.
 - f. LOW – 1400 RPM.
 - g. MED – 2100 RPM.
 - h. RUN – 2800 RPM.

NOTE: Do not increase the engine speed too fast as the air from the manifold could "blow-out" your fire.

"Less material more often will give you the fastest production rate."

LOADING AND STARTING THE T26 CHARBOSS (continued)

12. There is always smoke on start-up, as all of the material in the firebox contains moisture, compared to later in the burn operation when only the new material you are loading contains moisture. Plus, the air curtain cannot be fully engaged, until the fire has strengthened or you run the risk of blowing out the fire.
13. Do not load new material into the T26 CharBoss too fast during the first hour of burning operations until a good hot base has been achieved.
14. Once a good hot fire base is achieved load new material at a rate that causes good ignition and does not “smother” the fire.

CAUTION:

Do not ‘pack’ the feedstock into the firebox by pushing it down with the bucket or rake of a loader like an excavator or Bobcat, as this will damage the shaker panels and conveyor belt assembly.

DANGER:

Ensure there is no build-up of debris under the engine cowling or wheel fenders as this may create a fire hazard that could destroy your machine and may cause bodily injury or death.

“Less material more often will give you the fastest processing rate.”

T26 CharBoss Towable Air Curtain Burner for Biochar Processing (HATZ 3H50T Engine) OPERATING MANUAL

OPERATING THE T26 CHARBOSS

While the fire is being lit, fill the Quenching/Collection Bin with water, if not done already.

Once the fire is established usually within 30 minutes and the engine and air fan are running at the rated speed, the production of biochar can commence.



Quenching - Biochar Collection Bin

T26 CHARBOSS OPERATION

The following steps are performed from the main T26 CharBoss control panel.

1. Wait to operate Hydraulic System until fire is burning well and Fan Speed is at RUN – 2800 RPM.
2. Switch HYDRAULICS to ON.
3. Ensure SYSTEM PRESSURE is 1800 PSI.
4. Switch CONVEYOR and SHAKER to ON.
5. CONVEYOR and SHAKER will automatically cycle ON and OFF.
6. Biochar should start exiting the machine at the rear of the conveyor and dropping into the Quenching/Collection Bin.
7. Quench biochar completely.
8. Remove biochar from Catch Basin.
9. The Quenching/Collection Bin requires emptying every 10 to 15 minutes, depending on the rate that material is being introduced into the firebox. Turn the conveyor off at the control panel. Use a shuffle to move the biochar from the tray to a designated collection location. Wear appropriate PPE while performing this task.
10. The first collection bin or partial bin of biochar may contain a measurable amount of merely partially burned material and may be kept separate from the rest of the day's production, if desirable.



Strobe Warning Light

ATTENTION: Red strobe light indicates stalling of conveyor and/or shaker. See troubleshooting section for details.

T26 CHARBOSS OPERATION (Continued)



**Quenching Bin/Biochar Collection
Tray with Implements**



Char Exiting Conveyor Before Quenching

DANGER: Conveyor and shaker are automatically controlled by a timer and will start without warning during normal operation. Keep hands clear of moving parts, pinch points and hot areas.

DANGER: Persons working or standing in close proximity of Biochar exiting the conveyor must be mindful of the possibility that a sudden wind gust may force excessive hot air from the opening. Always wear suitable Personal Protective Equipment (PPE) while near the operating T26 CharBoss.



T26 CharBoss Towable Air Curtain Burner for Biochar Processing (HATZ 3H50T Engine) OPERATING MANUAL

HOW TO FEED A FIRE

It will generally take 30 minutes for the fire to build to a point where the temperatures are sufficient for the unit to be operating with minimal smoke.

1. Add material from your “Good Wood” pile slowly for the first hour. It takes about an hour for the fire to reach minimum temperature. Your goal is to achieve an even and hot fire across the unit.
2. For continuous operation the engine RPM is run at full throttle (preset at the factory).
3. Take caution when loading the unit that the material to be burned is not “dumped” into the firebox too quickly causing hot embers to be thrown from the unit. If you have an area in the firebox that is smoking, this indicates the temperature is low in that area. Add material from the “Good Wood” pile to get the fire temperature up. Once that area is burning add some of the heavier material.
4. The rate at which you load the unit varies depending on moisture content of the materials and the temperature of the fire. If you overload the firebox you will notice an increase in white smoke. White smoke is an indication that the temperature is dropping. If the smoke increases stop loading until the fire has caught-up. You can also bring the temperature up by adding materials from the “Good Wood” pile.
5. For the highest throughput load “*LESS MORE OFTEN.*” Smaller bucket loads more often will give the materials a better chance to ignite and will result in your highest throughput of material. Oversized bucket loads may smother the fire for a short period before it ignites this will slow the burning down and reduce your daily throughput.
6. The load in the firebox should not go higher than the bottom of the manifold. If the material is piled higher, it will begin to break the air curtain and more smoke will escape.

The fire should be loaded continuously throughout the day, in order to maintain operating temperatures. If the fire is not loaded continuously, the temperature will drop, the thru-put will go down and more smoke will escape.

WARNING:

PINCH POINT HAZARDS

Be mindful of Pinch Point Hazards. Keep your hands clear from all moving parts and hot parts of the T26 CharBoss while it is being set up or in operation.

“If it’s burning clean, it’s burning hot. If there is smoke, you’re losing money.”

SHUTDOWN

HOW TO BURN THE FIRE DOWN FOR SHUTDOWN

All loading should stop one hour before you intend shut down.

As the fire burns down, maintain the engine and fan speed. This is imperative to maintain the correct hydraulic flow for the shaker and conveyor. Do NOT stop the conveyor whenever there is a significant amount of heat in the machine.

The air in the manifold must continue to flow to control smoke (PM) emissions, to keep accelerating the burn-down, and to protect the manifold from warping from excessive heat. **DO NOT shut off the air flow while there are still flames within 12 inches of the manifold.** Doing so may cause elevated temperatures to warp the manifold, nozzle assembly, etc. Your warranty does NOT cover damage due to excessive heat.

Once the fire has burned down to ash it will be safe to prepare system shutdown following this shutdown sequence:

1. Ensure there is no fire in firebox.
2. Switch Conveyor and Shaker to OFF.
3. Switch System Power to OFF.
4. Press Button 2 – TURTLE to decrease fan speed (**See Page 14**).
5. Repeat until engine is running at IDLE – 900 RPM.
6. Press “ENGINE START – STOP” Button to stop engine.

Verify the fire inside is completely out. If it is still burning or smoldering you can raise the firebox and pull the trailer forward allowing the embers to stay behind, then water down any remaining embers. Ensure the fire is out and that there are no hot embers or biochar coals present and that the jobsite is secure before you leave.

DANGER:

Never transport the T26 CharBoss away and leave the burn site until you can absolutely ensure that all fires and embers have been completely extinguished. Caution: Look for trapped embers which may not be easily visible which could be blown by a wind gust to areas where they could start a fire.

ASH REMOVAL

HOW TO EMPTY THE T26 CHARBOSS

We recommend moving the unit every morning before burning operations begin. This will minimize the likelihood of fouling the conveyor operation and the ash will be easier to handle and there should be no hot coals or embers.

The ash is emptied by raising the firebox and towing the machine forward. If hot coals or embers are present in the ash bed, it is important to tow the machine away from the embers as soon as the firebox is raised to prevent the hot embers from damaging wheels, tires and axles. The machine should only be towed forwards as the tires cannot be driven through the hot embers.

DANGER: When removing wood ash or biochar from the T26 CharBoss, be aware of the wind direction and ensure all operators wear appropriate Personal Protective Equipment (PPE), including face masks (like respirators) to prevent inhaling anything harmful.

WOOD ASH CAUTION

Always wear appropriate Personal Protective Equipment (PPE), especially a breathing apparatus like a respirator while removing wood ash or biochar from the T26 CharBoss and while handling the wood ash or biochar.

Ash Removal

First, be familiar with Safety Section 7d on Page 8. [Click Here to Jump to Page 8](#)

1. Switch engine off.
2. Connect tow vehicle.
3. Raise jack stand.
4. Raise firebox into full up position and IMMEDIATELY pull forward leaving the hot embers and wood ash behind.
5. Before leaving the burn site, ensure the ash pile is not left behind HOT; you may use water gently on the ash pile to ensure all fire is out. Remember, not to spray water on the hot refractory thermal-ceramic panels as that could damage them.
6. Any residual wood ash can usually be land applied as a soil amendment.

DANGER: When removing ash from the firebox, move the T26 CharBoss forward swiftly as soon as the firebox is raised to prevent any hot embers from damaging the wheels, tires and axles.

T26 CHARBOSS TROUBLESHOOTING

1. Fire will not start

Material in firebox has too much air space. To correct, load heavy material to make the lower material pack down. **Do not pack the feedstock into the firebox or push down on it with machinery. The force may cause damage to the shaker panel and conveyor components.** Use torches and light from the bottom, so the fire burns up.

2. Fire burning at one end

Load “Good Wood” at end not burning and once “Good Wood” is burning, load heavier wood. Once that is burning continue normal operations.

3. Fire smoking too much

The most common reason for a smoking fire is loading it too fast, too much dirt or dense materials going into the firebox and reducing the heat. You must make sure the wood waste material is free from large amounts of dirt. Load from your “good wood” pile to bring the temperature back up. Loading new material too fast will smother the fire. Stop loading and let the fire catch up.

The material you are loading may have a very high moisture content. You can either load at a slower rate or mix the wetter material with dryer material.

4. Smoke from one area of the firebox

The area is probably not burning well. Add smaller material from your “good wood” pile to this area to help build the fire. As the smoke clears add heavier material.

5. Smoke from under the base rails or bottom of panels

Loose dirt was not properly shoveled around outside of firebox to seal between panel bottoms and the ground. To fix, shovel dirt around the outside where the smoke is escaping. Once the ash inside builds up this will stop.

WARNING:

PINCH POINT HAZARDS

Be mindful of Pinch Point Hazards. Keep your hands clear from all moving parts and hot parts of the T26 CharBoss while it is being set up or in operation.

T26 CHARBOSS TROUBLESHOOTING

DANGER:

Before troubleshooting the shaker or conveyor belt, wear Personal Protective Equipment (PPE), especially gloves and eye protection. Keep hands clear of hot and moving parts and pinch point hazard areas.

6. Shaker Stalls - Red Strobe Light Flashing

This can happen periodically under normal operations due to overloading or odd-shaped material causing the shaker table to bind up. Try shutting the SHAKER Switch off and waiting several minutes before turning it back on. Most times, once the material has burned down slightly and/or settled, the shaker will restart.

7. Conveyor Stalls - Red Strobe Light Flashing

Conveyor stalls are potentially more problematic as it is not desirable to have the conveyor stationary with a significant amount of heat in the machine. The T26 CharBoss has been fitted with a 1-1/8 inch drive shaft extension accepting a same size socket for manual operation with a standard hand ratchet. The extension is located on the right rear of the firebox as shown below.

- Turn off the CONVEYOR switch.
- First ensure the hand ratchet direction is set correctly (drive counter clockwise / CCW or “loosening”).
- Take a couple of partial turns on the driveshaft to ensure the shaft is being turned in the correct counter clockwise direction (CCW). Turn the CONVEYOR switch back on. If the conveyor does not restart, resume the manual assist at the driveshaft.



DANGER:

Conveyor and Shaker are automatically controlled by timer and start without warning during normal operation. Be aware of parts suddenly moving unexpectedly. Stay clear of all pinch point hazard areas and hot machine parts.

MAINTENANCE, CARE AND SAFETY CHECKS

1. First Week of Operation Check List: Axle Maintenance

This maintenance work requires that the trailer be chocked for safety, raised and supported by suitable jacks placed under the frame to a height that will relax the torsion springs and removal of each wheel. The firebox must be raised and the safety pins properly in place. This will allow access to the four (4) Bolts A and the large Bolt B. Hold the Bolts A topside with a wrench and tighten the bottom nut by torque wrench. See also NOTE below. Upon reinstallation of the wheels, torque the lug nuts to 80 ft-lb (109 N·m).

- a. Retorque the four (4) outboard arm (spindle) Bolts A to 155-165 ft-lb. (210-224 N·m).
- b. Retorque control arm pivot bolt B to 430-470 ft-lb. (583-638 N·m).
- c. Grease suspension bushing and wheel bearing every 6 months (off road use) or every 12,000 miles.

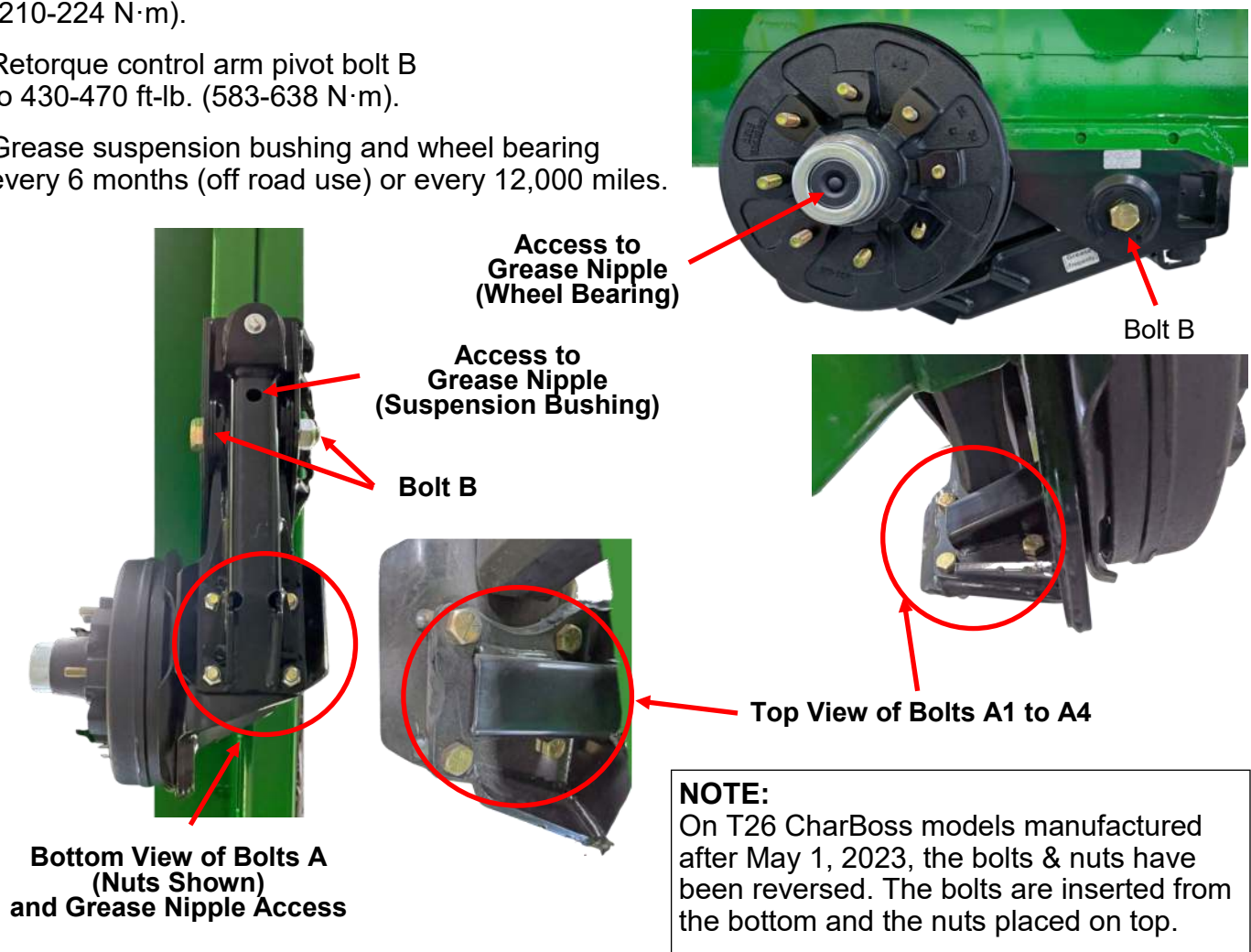

Wear suitable Personal Protective Equipment (PPE) while performing these tasks.

Check the proper torque of the Bolts A (1-4) and B and the wheel lugs periodically, especially before longer roadway travels. Grease the suspension bushing and wheel bearings with grease gun at the location indicated above. Rotate wheel by hand as grease is applied to bearing until old grease is visible. See Page 33 for lubricant grade.

MAINTENANCE, CARE AND SAFETY CHECKS

2. Daily Preoperational Check list:

- a. Oil level (top off as needed).
- b. Engine coolant level (top off as needed).
- c. Diesel fuel level in fuel tank.
- d. Tap dirt out of air intake housing and check for excessive dirt.
- e. Clean out any debris under engine cowling and wheel fenders.
- f. Ensure the hydraulic system is in proper condition, no leaks.

DANGER: Ensure there is no build-up of debris under the engine cowling or wheel fenders as this may create a fire hazard that could destroy your machine and may cause bodily injury or death. Wear PPE while performing these tasks.

3. Periodic Maintenance and Check List

- a. Change engine oil and oil filter as needed.
- b. Clean/replace fuel filter as needed.
- c. Clean and inspect air filter and replace as needed.
- d. Check lug nuts and torque to 80 ft-lb (109 N·m) to ensure they are tight.
- e. Clean debris off radiator.
- f. Check alternator V-belt and adjust as needed.
- g. Check tires for condition and set pressure at 105 psi (cold).
- h. Check break-away switch battery and steel cable.
- i. Check trailer hitch and safety chains.
- j. Check trailer brakes and all lights (adjust brakes by backing up T26 CharBoss and braking hard)
- k. Check lug nuts and torque to 80 ft-lb (109 N·m) to ensure they are tight.
- l. Grease axle suspension bushings until fresh grease exits both ends of control arm as described on Page 29.
- m. Grease wheel bearings until old grease is visible as described on Page 29.
- n. Check torque of axle bolts A (1-4) and B as described on Page 29.

Contact Air Burners, Inc., should you require assistance with any of these necessary maintenance tasks. Send Email to support@airburners.com, call 772-220-7303 or 888-566-3900 (Customer Service)

Consult the supplied HATZ Engine Service Manual.

ADJUSTING CONVEYOR BELT STATIC TENSION

DANGER: Ensure that the firebox is secured in the full UP Position with all safety pins properly in place before attempting to perform this procedure.

Procedure:

The “sag” or catenary at the rear of the conveyor belt provides the static tension for proper operation. **Do not attempt to tighten the belt to eliminate this sag.** The sag (and corresponding belt tension) MUST be adjusted correctly or damage to the machine will result.

1. With the firebox pinned in the full UP position, clamp a straight edge (piece of angle or similar) across the bottom of the Char Box at the approximate center point of the catenary (about 12” forward of the driveshaft centerline).
2. Measure the sag from the bottom of the belt to the bottom of the firebox and adjust it to 2½” as depicted in this drawing:

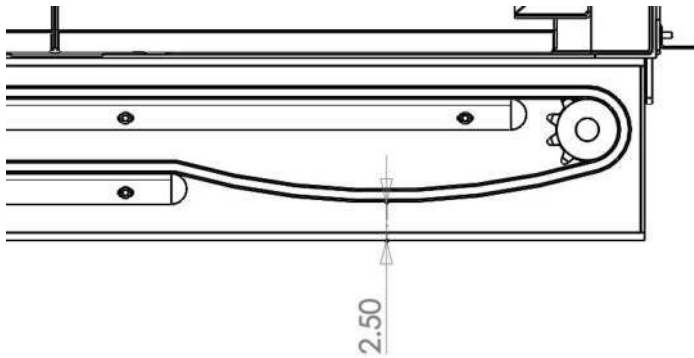

3. There is a belt tensioner on each side of the front of the T26 CharBoss where the idler shaft pillow block bearings are located. Loosen the locknut and adjust the belt tension up or down so that the chain just barely contacts the gauge block. Tighten the locknut. Repeat for the other side.

THERMAL- CERAMIC PATCHING COMPOUND

THERMAL- CERAMIC WET PRE-MIX PART # 6900-1003

For minor repair of Air Burners T26 CharBoss refractory panels.

Directions:

1. Cracking of the panels is normal as they flex in the heat. Filling the cracks every 6 months or as needed will extend the life of your Thermal-ceramic Panels.
2. Air Burners patching compound is pre-mixed and ready to use (may require some stirring).
3. Storage: Compound should be stored indoors in a frost free location.
4. Preparation: The area in and around the damaged area to be patched must be cleaned and brushed to provide the best surface for the compound to adhere. Remove all loose refractory and debris from the area to be patched.
5. Wet the cleaned surface with a light spray or damp cloth.
6. Installation: Using a trowel or similar tool, pack the refractory compound material into cracks and into areas where the refractory is missing. To achieve proper thickness trim off the excess material using a sharp flat blade or the side of the trowel.
7. Allow the material to harden overnight before placing the FireBox back into service. After the compound has hardened operate the T26 CharBoss under normal conditions.

NOTE:

***This is an air cured product. Reseal unused portion immediately.
Once opened the shelf life is one (1) year.***

CAUTION:

Never use water, for example from a fire hose, to extinguish the fire in the T26 CharBoss, except in a dire emergency. Water from a hose will tend to damage the hot refractory panels. Water from a normal rainfall would not damage the panels nor interfere with the operation of the T26 CharBoss.

WEAR PERSONAL PROTECTIVE EQUIPMENT (PPE):

Always wear appropriate Personal Protective Equipment (PPE) while working with the thermal ceramic patching compound repairing the refractory panels of the T26 CharBoss or while performing any other maintenance task on the machine.



**T26 CharBoss Towable Air Curtain Burner for Biochar Processing (HATZ 3H50T Engine)
OPERATING MANUAL**

SERVICING SPECIFICATIONS

**Parts List for Routine Service of
HATZ Industrial Diesel Engine 3H50T**

Also Refer to Engine Manufacturer's Service Manual for Engine Service Details
(Engine should be serviced after first 50 hours)

Description	Air Burners P/N	Manufacturer's P/N	Service Interval
Air Filter (Main Element H50)	5000-2338	HATZ 50638200	500 Hours
Air Filter (Secondary Element H50)	5000-2339	HATZ 50638300	500 Hours
Oil Filter H50	5000-2340	HATZ 50638800	500 Hours
Oil Separator H50 (Crank Case Vent)	5000-2341	HATZ 50640500	500 Hours
Main & Pre-Fuel Filter (Combined in Single Unit)	5000-3007	HATZ 2147501	500 Hours
Poly-V-Belt (Engine) H50	5000-2344	HATZ 50629401	500 Hours
Fuel/Water Separator Filter	5000-1297	RACOR R20P	As Needed
Hydraulic Fluid Filter Element	5000-2713	Donaldson P165762	As needed
Battery, 12V, Max 120 Ah; Max. CCA 800; Min. CCA 750; RC 130	5000-2472	Interstate Batteries 24M-XHD	As Needed

Tire Pressure	105 psi (724 kPa) Cold
Tire Size	ST235/80R16
Rim	16 x 6 (8 Lugs)
Fuel	Ultra-low Sulfur Diesel Fuel
Engine Oil	15W40 or 10W40 Diesel Grade
Engine Oil Capacity	5.2 qt. (4.9 L)
Engine Coolant	Low Silicon Anti-Freeze (Green). Units are shipped from factory with 50-50 mixture green antifreeze/water.
Hydraulic Oil	ISO32 Synthetic Hydraulic oil, factory installed is Amsoil HVH05-EA. (cold weather option is ISO22 synthetic, i.e. Amsoil HVG05EA). Change Hydraulic Oil every 1 to 2 years, depending on environment.
Hydraulic Oil Capacity	3.3 gal. (12.5 L)
Break-Away Switch	12V Battery - See owner's manual
Fuel Tank Capacity	Minimum 20 Gallons (75.7 Liters)
Hi-Temp Anti-Seize	Electrically Conductive Anti-Seize Lubricant, -65°F to 2000°F

APPENDIX

Pages 1 & 2

T26 CharBoss® Trailer Lighting & Brake Wiring Schematic

The T26 CharBoss® is equipped with electric brakes on all six wheels. The brakes will adjust automatically each time the T26 CharBoss is backed up.

The brakes have been properly adjusted at the Factory, but it is the operator's responsibility to keep them adjusted by periodically backing up the T26 CharBoss while applying the brakes hard.

APPENDIX

Page 3

T26 CharBoss® Trailer Lifting Points and Tie Down D-Rings

NOTICE: Crane lifting and trailer tie downs must be accomplished by certified crane operators, riggers and truck operators. The information provided in this section is intended to be general guidelines and suggestions, not instructions or advice.

Tasks such as securing a load like the T26 CharBoss to a transport vehicle or lifting it by crane or other machinery for whatever purpose are the sole responsibilities of the respective professional operators.

All persons in the immediate vicinity of the crane and transport vehicle must wear appropriate Personal Protective Equipment (PPE).

The T26 CharBoss has been designed for transport as a legal load in the US on standard 102 in. wide flatbed trailers. In most instances the roll-on/roll-off method (RoRo) is used by backing up the flatbed trailer against a loading dock of suitable height. If this method cannot be employed for unloading at a destination, crane lifting is an alternative method.

The T26 CharBoss has been fitted with hoist rings for crane lifting and D-rings on the trailer frame for tie downs on transport flatbed trailers.

For crane lifting, a properly rated spreader bar must be used if unloading by crane is planned. An example of a spreader bar is shown on [Appendix B Page 3](#).

APPENDIX

Page 4

T26 CharBoss® HATZ Diesel 3H50T Engine Overview

The engine overview shows the HATZ 3H50T Diesel Engine with its main components (the position of some components may vary slightly). The 3H50T is a Turbo Diesel Engine.

T26 CharBoss® Trailer Lighting & Brake Wiring Schematic

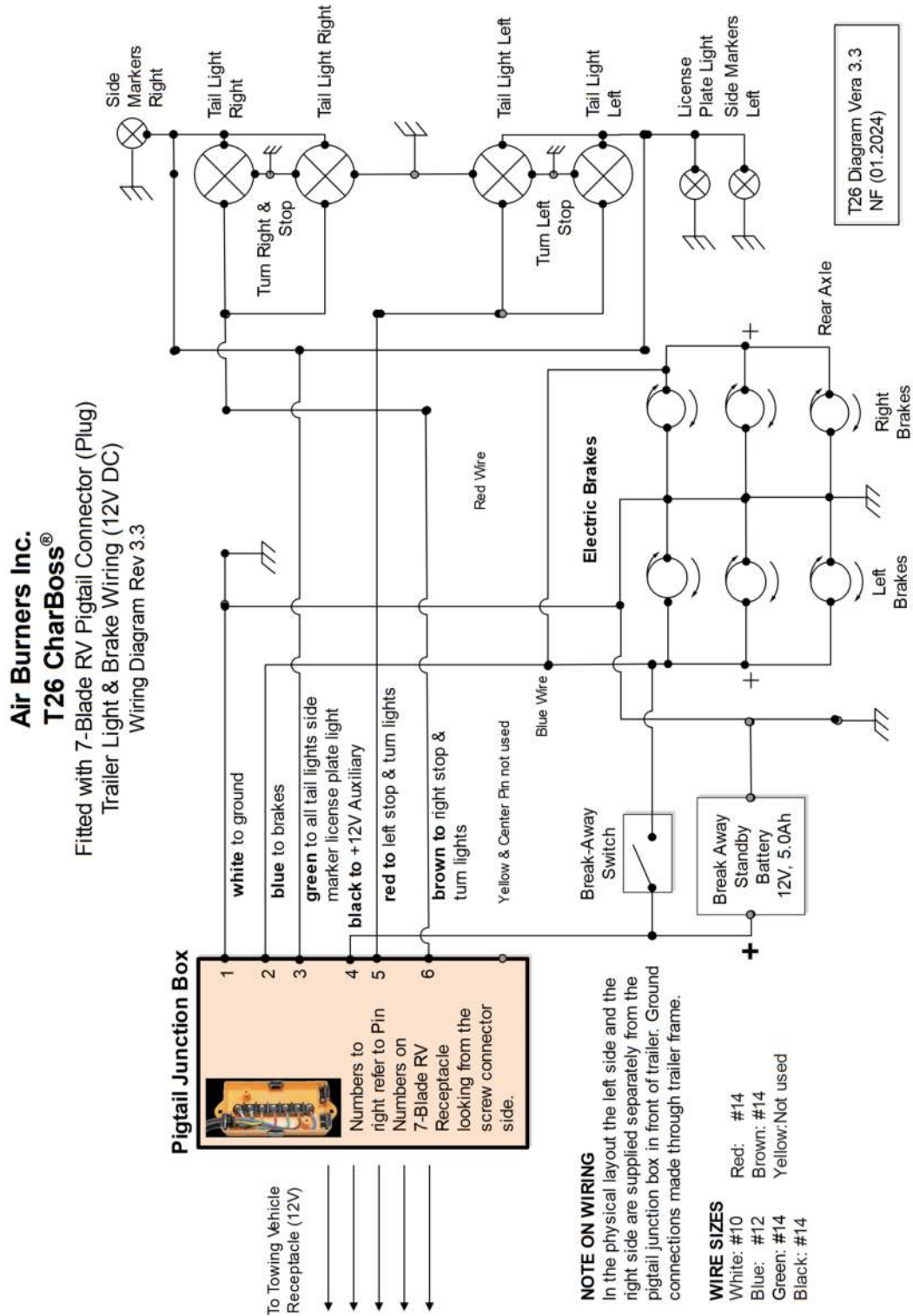

T26 CharBoss® Trailer Lighting & Brake Wiring Schematic



7-Blade RV Type Trailer Wiring Connector

(Looking from Screw Connector Side - Back of Plug)

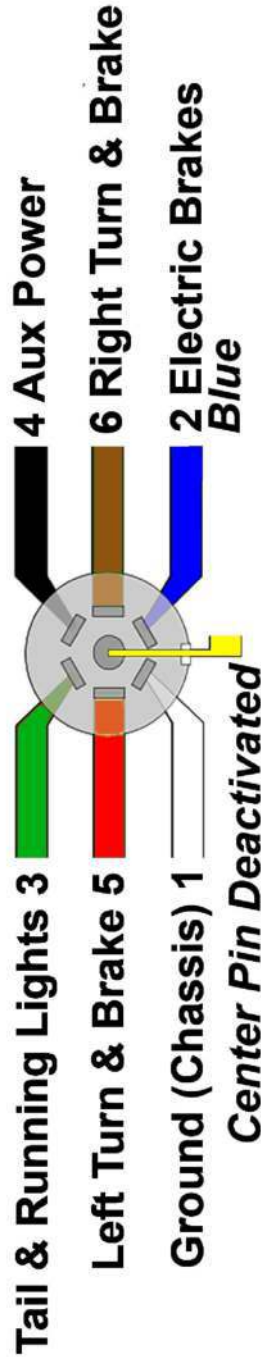

Blade #4 Connects to Break-Away Switch to Supply +Power from Towing Vehicle

Configuration Applies to CharBoss® T26 (Dec. 2023 Build)

Rev. 3.2 (05 DEC 2023)

T26 CharBoss® Trailer Lifting Points and D-Rings for Tie Downs

A. Crane Lifting:

The T26 CharBoss is fitted with four (4) hoist rings mounted near the four corners of the upper rails of the trailer frame. Lifting string straps must **only** be attached to these lifting points and **only** with an appropriate spreader bar of proper length and rated for lifting the T26 CharBoss trailer weight of approximately 9 tons.

Crane operators and riggers must follow all rules and regulations of the respective authorities for the operation of their equipment in their jurisdictions to ensure safe crane lifting of the T26 CharBoss, as improper procedures may cause an accident that may result in property damage and injury or death.



Rear Lifting Points and T26 Spreader Bar

B. Tie Downs:

The T26 CharBoss is shipped with the firebox secured in the UP (raised) position. A disposable sturdy “helper stand” is provided that accommodates the ball coupler. The built-in jack stand should not be used to support the T26 CharBoss while it is being trucked, as it may suffer damage from the force put on it by the chain binders. The quenching tray and other implements must be separately secured to the transport vehicle away from the T26 CharBoss.

Chain binders (or straps) must only be attached to the four D-rings fitted to the trailer frame. Never use straps over the engine cowling, the manifold/firebox or any other location as that could result in serious damage to the machine. A strap over the front of the ball coupler with “helper stand” in place is acceptable.

Truckers and riggers must follow all rules and regulations of the respective authorities for the operation of their equipment to ensure safe securing of the T26 CharBoss to their transport equipment, as improper procedures may cause an accident that may result in property damage and injury or death.



D-Rings

T26 CharBoss® HATZ Diesel 3H50T Engine Overview

